

Singer 16-188

Form 8933
(Rev. 558)
Printed in U.S.A.

LIST OF PARTS



SINGER**

MACHINE No. 16-188

THE SINGER MANUFACTURING COMPANY

** A Trademark of THE SINGER MANUFACTURING COMPANY

INSTRUCTIONS FOR OILING

To ensure easy running and prevent unnecessary wear of the parts which are in movable contact, the machine requires oiling and when in continuous use, "TYPE B" or "TYPE D" OIL, sold by Singer Sewing Machine Company, should be applied at least twice each day to all oil holes marked "OIL", as instructed in Form 7615.

"TYPE D" OIL should be used when an oil is desired which will produce a minimum of stain on fabrics, even after a long period of storage.

Apply a few drops of oil to the shuttle bearings in the shuttle race each time a bobbin is replaced.

Copyright © 1958 by The Singer Manufacturing Company

INDEX

	Page
Accessories	13
Binders	13
Bobbin Winders	15
Corders	18
Edge Folder	19
Finger Guards	20
Fittings	20
Hemmers	20
Knee Lifter Parts	25
Machine No. 16-188	7
Numerical List of Parts	27
Thread Unwinder	25

INSTRUCTIONS FOR ORDERING

In ordering from this list, use ONLY the part NUMBER in the FIRST column.

The number stamped on a Sewing Machine Part is in every case the number of the single part only.

Every combination of parts sent out as such has its specific number, which, although not stamped on the parts, must be used when ordering the combination.

Each number always indicates the SAME PART in whatever list it appears, or for whatever machine.

The letters after some of the numbers indicate the style of finish only, as follows:

- A—Hardened, Polished, Nickel Plated and Buffed
- B—Polished, Nickel Plated and Buffed
- C—Hardened Only
- D—Polished Only
- E—Soft, Not Polished
- F—Hardened and Polished
- G—Bright Rumbled and Nickel Plated
- H—Blued
- J—Nickel Plated Only
- K—Hardened and Nickel Plated
- L—Brass Plated
- M—Oxidized
- R—Phosphate Coating Formed on Surface of Iron or Steel
- S—Cadmium Plated
- T—Copper Plated
- U—Zinc Plated
- V—Silver Plated
- W—Polished and Nickel Plated
- X—Black Oxide for Iron and Steel
- Y—Black Nickel Plated Only
- Z—Chromium Plated
- A.A—Buffed and Chromium Plated
- A.B—Hardened, Polished, Buffed and Chromium Plated
- A.E—Hardened, Bright Rumbled and Nickel Plated
- A.F—Hardened, Bright Rumbled, Nickel Plated, Bright Rumbled and Chromium Plated
- A.G—Alumilite (Plain)
- A.H—Alumilite (Dyed) Color Must be Stated
- A.J—Polished, Nickel Plated and Chromium Plated
- A.K—Hardened, Polished, Nickel Plated and Chromium Plated
- A.L—Heat Treated for Toughness
- A.L.D—Heat Treated for Toughness and Polished
- A.L.X—Heat Treated for Toughness and Black Oxide

INSTRUCTIONS FOR ORDERING

- A.S—Black Moulded Phenolic
 - A.T—Beige Moulded Phenolic
 - A.U—Brown Moulded Phenolic
 - A.W—Hardened then Flame Coated with Tungsten Carbide
 - B.A—Chrome Nickel Satin Finish
 - B.B—Hardened and Chrome Nickel, Satin Finished
 - C.R—Hardened and Phosphate Coating Formed on Surface of Steel
 - F.J—Hardened, Polished and Nickel Plated
 - T.A—Hardened, Polished, Copper and Nickel Plated and Buffed
 - T.B—Copper and Nickel Plated and Polished
 - T.J—Copper and Nickel Plated Only
 - T.K—Hardened, Copper and Nickel Plated
 - T.L—Copper and Brass Plated
 - T.M—Copper Plated and Oxidized
 - X.C—Hardened and Black Oxide for Iron and Steel
 - Z.A—Hardened, Polished Nickel Plated, Buffed and Chromium Plated
 - Z.B—Polished, Nickel Plated, Buffed and Chromium Plated
 - Z.C—Hardened and Chromium Plated
 - Z.D—Polished and Chromium Plated
 - Z.G—Bright Rumbled, Nickel Plated, Bright Rumbled and Chromium Plated
 - Z.I—Nickel and Chromium Plated
 - Z.T—Copper and Chromium Plated
- These letters MUST BE USED when they appear in the list; and AFTER the number as in the list.
- In this series:
- 1 to 1500, 50001 to 51500 and 140001 to 142,000 are screw numbers
 - 1501 to 1800 and 51501 to 51800 are nut numbers
 - 1801 to 2000 and 51801 to 52000 are roller numbers
 - 2001 to 50000 and 52001 to 140000 and 142001 to 190000 are Sewing Machine Parts, 190001 and upward are numbers of Electrical Parts.
- The figures in the second column refer only to the plates, illustrating the parts, and are NOT TO BE USED in ordering.
- Parts marked with an asterisk (*) are furnished only when repairs are made at the factory.

LIST OF PARTS COMPLETE
FOR

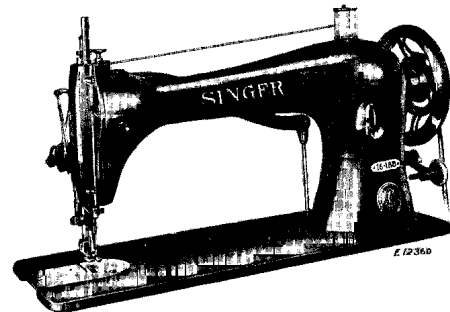

MACHINE No. 16-188

CENTRAL BOBBIN. HIGH LIFT. INDEPENDENT UPPER AND UNDER FEED

No.	Plate	Name
* 4890	-----	Arm with 159D, 180D, 4448, 4449, 4891, 4892, 6305 and four 129D.....
2002	24160	Arm Dowel Pin (2).....
4448	24160	Arm Oil Tube for intermediate bearing...
123E	24160	Arm Screw (3).....
4359	24161	Arm Shaft.....
56811	-----	Arm Shaft 4359 with 4745 and 56829.....
3005	24161	Arm Shaft Bushing (back).....
140732AL	24161	Arm Shaft Bushing (back) Set Screw.....
4449	24161	Arm Shaft Bushing (front).....
144D	24161	Arm Shaft Screw.....
4743	24160	Arm Side Cover.....
51224W	24160	Arm Side Cover Thumb Screw.....
52239	24160	Arm Spool Pin and Thread Eyelet.....
8879	24160	Arm Spool Pin Washer (cloth).....
		NOTE: When ordering No. 8879, state color required.
* 80982	-----	Bed.....
4292	24161	Crank Connecting Rod with 125044 and two 145E.....
145E	24161	Crank Connecting Rod Cap Screw (2)....
375C	24161	Crank Connecting Rod Hinge Screw.....
1518J	24161	Crank Connecting Rod Hinge Screw Nut...
125044	24161	Crank Connecting Rod Oil Pad (felt)....
56871	24162	Face Plate.....
56872	-----	Face Plate 56871 with 2105.....
56873	-----	Face Plate complete, Nos. 448AL, 460AL, 2111, 2127, 2269, 4378, 56791, 56870, 56872 and two 233J.....

No.	Plate	Name
175D	24162	Face Plate Screw (3)
56870	24162	Face Plate Thread Guard
233J	24162	Face Plate Thread Guard Screw
439I	24163	Feed (lower) Bar
313C	24163	Feed (lower) Bar Screw Center (2)
56813	-----	Feed (lower) Bar Screw Center 313C with 1519J (2)
1519J	24163	Feed (lower) Bar Screw Center Nut (2)
4745	24161	Feed (lower and upper) Cam with 448AL
448AL	24161	Feed (lower and upper) Cam Set Screw
52165	24161	Feed (lower) Connecting Link
375C	24161	Feed (lower) Connecting Link Hinge Screw (2)
1518J	24161	Feed (lower) Connecting Link Hinge Screw Nut (2)
3037	24161	Feed (lower) Forked Connection
5748	-----	Feed (lower) Forked Connection complete, Nos. 3037, 52165, 56894 and two each 375C and 1518J
375C	24161	Feed (lower) Forked Connection Hinge Screw
1518J	24161	Feed (lower) Forked Connection Hinge Screw Nut
3165	24163	Feed (lower) Lifting Rock Shaft
3163	-----	Feed (lower) Lifting Rock Shaft complete, Nos. 3165 and 3166
3166	24163	Feed (lower) Lifting Rock Shaft Crank with 157E and 1813
157E	24163	Feed (lower) Lifting Rock Shaft Crank Clamping Screw
1904	24163	Feed (lower) Lifting Rock Shaft Crank Roller
1813	-----	Feed (lower) Lifting Rock Shaft Crank Roller and Stud Nos. 1904 and 125060
125060	24163	Feed (lower) Lifting Rock Shaft Crank Roller Stud
307C	24163	Feed (lower) Lifting Rock Shaft Screw Center (2)
56814	-----	Feed (lower) Lifting Rock Shaft Screw Center 307C with 1513J (2)
1513J	24163	Feed (lower) Lifting Rock Shaft Screw Center Nut (2)
4747	24161	Feed (lower) Regulator
56894	-----	Feed (lower) Regulator 4747 with 818W
140139E	24161	Feed (lower) Regulator Hinge Screw
139603	24161	Feed (lower) Regulator Hinge Screw Friction Washer
818W	24161	Feed (lower) Regulator Thumb Screw
3042	24163	Feed (lower) Rock Shaft
56880	-----	Feed (lower) Rock Shaft complete, Nos. 3042 and 29633
29633	24163	Feed (lower) Rock Shaft Crank with 157R
157R	24163	Feed (lower) Rock Shaft Crank Set Screw
307C	24163	Feed (lower) Rock Shaft Screw Center (2)

No.	Plate	Name
56814	-----	Feed (lower) Rock Shaft Screw Center 307C with 1513J (2)
1513J	24163	Feed (lower) Rock Shaft Screw Center Nut (2)
4744	24164	Feed (upper) Bar
6306	24164	Feed (upper) Bar Connecting Link
89F	24164	Feed (upper) Bar Connecting Link Hinge Screw (2)
2361	24164	Feed (upper) Bar Hinge Bracket
2362	24164	Feed (upper) Bar Hinge Bracket Rivet (2)
810D	24164	Feed (upper) Bar Hinge Cap Screw
4746	24165	Feed (upper) Forked Connection with 453AL
3093	24165	Feed (upper) Forked Connection Pin
453AL	24165	Feed (upper) Forked Connection Set Screw
4904	24165	Feed (upper) Lever
* 6305	-----	Feed (upper) Lever Bracket with two 620AL
180D	24165	Feed (upper) Lever Bracket Screw (lower)
159D	24165	Feed (upper) Lever Bracket Screw (upper)
6307	24165	Feed (upper) Lever Hinge Pin
620AL	24165	Feed (upper) Lever Hinge Pin Set Screw (2)
56904	24165	Feed (upper) Regulator
4938	-----	Feed (upper) Regulator complete, Nos. 666F, 1014D, 4907, 4959, 13076, 56904 and two 237AL
2049	24165	Feed (upper) Regulator Pin
13076	24165	Feed (upper) Regulator Slide Block
1014D	24165	Feed (upper) Regulator Thumb Screw
666F	24165	Feed (upper) Regulator Thumb Screw Lock Screw
4959	24165	Feed (upper) Regulator Thumb Screw Lock Stud (brass)
4907	24165	Feed (upper) Regulator Thumb Screw Stop Bracket
237AL	24165	Feed (upper) Regulator Thumb Screw Stop Bracket Screw (2)
4908	24165	Feed (upper) Shaft
56774	-----	Feed (upper) Shaft 4908 with 2049, 4746 and 4938
4892	24165	Feed (upper) Shaft Bracket (back)
129D	24165	Feed (upper) Shaft Bracket (back) Screw (2)
4891	24165	Feed (upper) Shaft Bracket (front)
129D	24165	Feed (upper) Shaft Bracket (front) Screw (2)
4642	24166	Feed Dog 16 teeth (16 teeth to the inch)
56845	-----	Feed Dog (spiked teeth)
		NOTE: No. 4642 is regularly furnished.
208AL	24166	Feed Dog Screw (2)
56896	24166	Feeding Foot
217D	24166	Feeding Foot Screw
25875	24166	Guide

No.	Plate	Name
3126	24164	Guide Bar
56752	-----	Guide Bar 3126 with 2361 and two 2362 ...
4899	-----	Guide Bar complete, Nos. 810D, 810E, 4723, 4744, 4897, 56752 and three 404J ...
4854	24167	Guide Bar Driving Crank with 1862 and 3131
1862	24167	Guide Bar Driving Crank Roller (roller only)
3131	24167	Guide Bar Driving Crank Roller Cap
3094	-----	Guide Bar Driving Crank Wedge
5750	-----	Guide Bar Driving Crank Wedge 3094 with 690E
690E	24161	Guide Bar Driving Crank Wedge Screw ...
4723	24164	Guide Bar Lifting Bracket
404J	24164	Guide Bar Lifting Bracket Screw (3) ...
284D	24166	Guide Thumb Screw
2058	24168	Lifting Presser Bar
3133	24168	Lifting Presser Bar Bracket with 641E and 1823
641E	24168	Lifting Presser Bar Bracket Clamping Screw
1823	24168	Lifting Presser Bar Bracket Roller and Stud
4909	24168	Lifting Presser Bar Lifter
598C	24168	Lifting Presser Bar Lifter Screw
4897	24164	Lifting Presser Bar Lifting Bell Crank ...
810E	24164	Lifting Presser Bar Lifting Bell Crank Hinge Cap Screw
4725	24168	Lifting Presser Bar Lifting Bracket
4726	24168	Lifting Presser Bar Lifting Bracket Guide Pin
56903	24168	Lifting Presser Bar Spring
		NOTE: No. 56903 is regularly furnished.
32675	-----	Lifting Presser Bar Spring (light)
3100	-----	Lifting Presser Bar Spring (heavy)
8225	-----	Lifting Presser Bar Spring (extra heavy)
2070	24168	Lifting Presser Bar Spring Washer
5792	24166	Lifting Presser Foot
217D	24166	Lifting Presser Foot Screw
56898	24161	Machine Pulley (heavy rim) "V" Belt Groove (Outside Diam. of Belt Groove 2, 9 in.) with two 435AL
435AL	24161	Machine Pulley Set Screw (2)
4264	24167	Needle Bar
4898	24167	Needle Bar Connecting Link with 390E ...
56764	-----	Needle Bar Connecting Link 4898 with 15472
390E	24167	Needle Bar Connecting Link Adjusting Screw
15472	24167	Needle Bar Connecting Stud with 155C ...
155C	24167	Needle Bar Connecting Stud Set Screw ...
4265	24167	Needle Clamp with 196AL
4865	24167	Needle Clamp complete, Nos. 651D, 4265 and 4266

No.	Plate	Name
196AL	24167	Needle Clamp Screw
4266	24167	Needle Clamp Thread Guide
651D	24167	Needle Clamp Thread Guide Screw
4304	24161	Oscillating Rock Shaft (steel) with 4784 ...
5747	-----	Oscillating Rock Shaft 4304 with 15489 and 56812
3052	24161	Oscillating Rock Shaft Hinge Pin
56812	-----	Oscillating Rock Shaft Hinge Pin 3052 with 1513J
1513J	24161	Oscillating Rock Shaft Hinge Pin Nut
635C	24161	Oscillating Rock Shaft Hinge Pin Screw Bearing
15489	-----	Oscillating Rock Shaft Hinge Pin Screw Bearing 635C with 1513J
1513J	24161	Oscillating Rock Shaft Hinge Pin Screw Bearing Nut
4784	24161	Oscillating Rock Shaft Oil Pad
3168	24163	Oscillating Shaft
15426	24163	Oscillating Shaft Crank
15165	-----	Oscillating Shaft Crank complete, Nos. 1519E, 15171, 15426 and two 462AL
462AL	24163	Oscillating Shaft Crank Set Screw (2) ...
15170	24163	Oscillating Shaft Crank Slide Block
226J	24163	Oscillating Shaft Crank Slide Block Cap Screw
12424	24163	Oscillating Shaft Crank Slide Block Cap Screw Washer
1035C	24163	Oscillating Shaft Crank Slide Block Screw Stud
1519E	24163	Oscillating Shaft Crank Slide Block Screw Stud Nut
15171	-----	Oscillating Shaft Crank Slide Block complete, Nos. 226J, 1035C, 12424 and 15170
262J	24168	Pressure Regulating Thumb Screw
1632C	24168	Pressure Regulating Thumb Screw Lock Nut
2996	24169	Shuttle Bobbin
15140	24169	Shuttle Bobbin Case
2973	24169	Shuttle Bobbin Case Latch
2974	24169	Shuttle Bobbin Case Latch Lever Fulcrum Pin
2975	24169	Shuttle Bobbin Case Latch Spring
592E	24169	Shuttle Bobbin Case Latch Stop Screw ...
15141	-----	Shuttle Bobbin Case Hinge with 2973, 2974 and 15140
15277	24169	Shuttle Bobbin Case with 591F, 592E, 2975, 15141 and 15278
2515	24169	Shuttle Body
15100	24169	Shuttle, 1 11/16 in. diam., Nos. 2515, 2996 and 15277
68752	24163	Shuttle Driver with two 462AL
462AL	24163	Shuttle Driver Set Screw (2)
2531	24170	Shuttle Race Back

No.	Plate	Name
2532	24170	Shuttle Race Back Position Pin (2).....
2533	24170	Shuttle Race Back Spring.....
648J	24170	Shuttle Race Back Spring Screw.....
2530	24170	Shuttle Race Body.....
15420	-----	Shuttle Race Body 2530 with 2535 and two 662AL.....
2535	24170	Shuttle Race Cap.....
662AL	24170	Shuttle Race Cap Screw (2).....
56897	24170	Shuttle Race complete, Nos. 648J, 2531, 2533, 15420 and two 2532.....
145B	24170	Shuttle Race Screw (2).....
4305	24160	Shuttle Race Slide.....
80528	24160	Shuttle Race Slide complete, Nos. 2824, 4305 and two 51282E.....
2824	24160	Shuttle Race Slide Spring.....
51282E	24160	Shuttle Race Slide Spring Screw (2).....
591F	24169	Shuttle Tension Regulating Screw.....
15278	24169	Shuttle Tension Spring.....
2102	24171	Tension Disc (2).....
56791	24171	Tension complete, Nos. 2103, 2124, 16202 and two 2102.....
4378	24162	Tension Releaser.....
2269	24162	Tension Releaser Hinge Pin.....
1560C	24171	Tension Regulating Thumb Nut.....
600C	24171	Tension Screw Stud.....
16202	-----	Tension Screw Stud 600C with 1560C.....
448AL	24162	Tension Screw Stud Set Screw.....
2103	24171	Tension Spring.....
2105	24162	Tension Thread Guard.....
2112	24171	Thread Retaining Disc with 2113.....
2113	24171	Thread Retaining Disc Steady Pin.....
2114	24171	Thread Retaining Spring.....
2115	24171	Thread Retaining Stud.....
460AL	24162	Thread Retaining Stud Set Screw.....
2111	24171	Thread Retaining Guide complete, Nos. 2112, 2114 and 2115.....
56829	24161	Thread Take-up Cam (steel).....
3012	24161	Thread Take-up Cam Pin.....
3072	24167	Thread Take-up Lever with 1819.....
56855	-----	Thread Take-up Lever 3072 with 1088C.....
1088C	24167	Thread Take-up Lever Hinge Screw.....
1819	24167	Thread Take-up Lever Roller and Stud.....
2124	24171	Thread Take-up Spring.....
2127	24171	Thread Take-up Spring Regulator Plate.....
233J	24171	Thread Take-up Spring Regulator Plate Adjusting Screw.....
4646	24166	Throat Plate, large needle hole.....
56836	-----	Throat Plate, small needle hole.....
		NOTE: No. 4646 is regularly furnished with this Machine.
691AL	24166	Throat Plate Screw (2).....
139637	-----	Drip Pan with four 1 in. wire nails.....

ACCESSORIES

No.	Plate	Name
27136	24153	Machine Button with wood screws 1-1/2 in. No. 14 R.H.B.....
12361	24153	Machine Hinge Connection (2).....
41400	24153	Machine Rest Pin (wood).....
120342	24153	Oiler (copper plated) with 120343.....
120343	24153	Oiler Spout, 3-1/2 in. long.....
26026	24153	Screw Driver (machine).....
26485	24153	Screw Driver (shuttle tension).....
4347	24153	Wrench for 1513 and 1518.....
4918	-----	Wrench for 1632.....
8908	24153	Wrench for 1519 and 1520.....

BINDERS

BINDER ON SHANK

For 7/16 in. to 3/4 in. binding, in steps of 1/16 in.

No.	Plate	Name
161286	24172	Binder on Shank with two each 217J and 7071, for 7/16 in. to 3/4 in. binding, in steps of 1/16 in.
		NOTE: When ordering furnish a finished sample and materials for testing or state size of binding or tape.
217J	24172	Binder Screw (2).....
190J	24172	Binder Screw (to bed of machine) (2)....
7071	24172	Binder Screw Washer (to bed of machine) (2).....
7071	24172	Binder Screw Washer (2).....
121746	24172	Binder Shank Leveling Plate for use with 161286.....
35227	24172	Feed Dog, 20 teeth (16 teeth to the inch)...
35181	24172	Feeding Foot.....
35230	24172	Lifting Presser Foot.....
35229	24172	Throat Plate.....

BINDER ON SHANK

For 13/16 in. to 1 3/8 in. binding, in steps of 1/16 in.

No.	Plate	Name
161287	24173	Binder on Shank with two each 217J and 7071, for 13/16 in. to 1-3/8 in. binding, in steps of 1/16 in.
NOTE: When ordering, furnish a finished sample and materials for testing or state size of binding or tape.		
217J	24173	Binder Screw (2)
190J	24173	Binder Screw (to bed of machine) (2)
7071	24173	Binder Screw Washer (to bed of machine) (2)
7071	24173	Binder Screw Washer (2)
121746	24173	Binder Shank Leveling Plate
35227	24173	Feed Dog, 20 teeth (16 teeth to the inch)
35181	24173	Feeding Foot
35230	24173	Lifting Presser Foot
35229	24173	Throat Plate

BINDER ON SHANK

For 1 in. to 1 3/4 in. binding, in steps of 1/16 in.

No.	Plate	Name
161288	24174	Binder on Shank with two each 217J and 7071, for 1 in. to 1-3/4 in. bindings, in steps of 1/16 in.
NOTE: When ordering, furnish a finished sample and materials for testing or state size of binding as well as size of finish.		
217J	24174	Binder Screw (2)
190J	24174	Binder Screw (to bed of machine) (2)
7071	24174	Binder Screw Washer (to bed of machine) (2)
7071	24174	Binder Screw Washer (2)
121746	24174	Binder Shank Leveling Plate
161289	24174	Feed Dog (spiked teeth)
36346	24174	Feeding Foot

BINDER ON SHANK

No.	Plate	Name
160942	24174	Lifting Presser Foot
36465	24174	Lifting Presser Foot (right hand spring guide) 160942 with 665J and 36464
36464	24174	Lifting Presser Foot Spring Guide
665J	24174	Lifting Presser Foot Spring Guide Screw
35229	24174	Throat Plate

BOBBIN WINDERS

**BOBBIN WINDER
(Tight Wheel)**

No.	Plate	Name
5522	24175	Frame
2460	24175	Friction Ring (rubber)
2461	24175	Pulley
5529	24175	Spindle
5530	----	Spindle 5529 with 2461
2464	24175	Spring
5528	24175	Bobbin Winder (tight wheel) complete, Nos. 2460, 5522 and 5530
46D	24175	Bobbin Winder Hinge Screw

**BOBBIN WINDER
(Swinging Automatic, Right Hand)
For V-Belt Drive**

No.	Plate	Name
27540	24175	Base
15072	24175	Bobbin Position Pin
27302	24175	Frame
50356D	24175	Frame Hinge Screw
1620J	24175	Frame Hinge Screw Nut
27303	----	Frame Spring
150785	24175	Pulley
27538	24175	Spindle with 15072 and 41828
41828	24175	Spindle Collar Pin
27306	24175	Spool Pin
27307	24175	Spool Stand
27308	24175	Spool Stand complete, Nos. 418E, 1562J, 2106, 10141, 11241, 27306, 27307 and two each 2455 and wood screws 1 in. No. 10.
11241	24175	Spool Washer (cloth)
27312	24175	Stop Latch
35D	24175	Stop Latch Hinge Screw
2455	24175	Tension Disc (2)
1562J	24175	Tension Regulating Thumb Nut
418E	24175	Tension Screw Stud
10141	24175	Tension Spring
2106	24175	Tension Thread Guide

BOBBIN WINDER

No.	Plate	Name
150788	24175	Bobbin Winder, Nos. 35D, 1620J, 2730Z, 27303, 27312, 27538, 27540, 50356D, 150785 and two wood screws 1 in. No. 7 F. H.
150789	24175	Bobbin Winder (swinging automatic, right hand) complete, "V" belt drive, Nos. 27308 and 150788.

BOBBIN WINDER
(Swinging Automatic, Right Hand)
For V-Belt Drive
For Power Table.

No.	Plate	Name
259428	23253	Brake (leather)
259429	23253	Brake Clamp
200113F	23253	Brake Clamp Screw
259662	23253	Bobbin Winder and Tension Bracket Base
225453	23253	Frame with 202277 and 259660
225454	23253	Frame Hinge Pin
202277	23253	Frame Oil Packing (wick)
259660	23253	Frame Oil Well Washer
225455	23253	Frame Spring
225456	23253	Frame Spring Plunger
259461	23253	Pulley with 200380C
200380C	23253	Pulley Set Screw
225381	23253	Spindle
225444	23253	Stop Latch
200056E	23253	Stop Latch Screw
225458	23253	Stop Latch Thumb Lever
225459	23253	Stop Latch Thumb Lever Hinge Stud
225459	23253	Stop Latch Thumb Lever Joint Stud
202478	23253	Stop Latch Trip Lever
200299B	23253	Stop Latch Trip Lever Hinge Screw
225461	23253	Tension Bracket with 201499B
200082D	23253	Tension Bracket Screw
228026	23253	Tension Bracket Screw Washer
2102	23253	Tension Disc (2)
13710	23253	Tension Spring
201499B	23253	Tension Stud
201572B	23253	Tension Stud Thumb Nut
225462	23253	Tension Bracket complete, Nos. 13710, 201572B, 225461 and two 2102
259462	23253	Bobbin Winder Swinging Auto right hand etc. complete, for "V" belt, Nos. 200056E, 200082D, 200113F, 200299B, 202478, 225381, 225444, 225453, 225454, 225455, 225456, 225458, 225462, 228026, 259428, 259429, 259461, 259662, and two each 225459 and wood screws 3/4 in. No. 12 R. H.

BOBBIN WINDER
(For Round Belt)

No.	Plate	Name
259428	23253	Brake (leather)
259429	23253	Brake Clamp
200113F	23253	Brake Clamp Screw
259430	23253	Bobbin Winder and Tension Bracket Base
225453	23253	Frame with 202277 and 259660
225454	23253	Frame Hinge Pin
202277	23253	Frame Oil Packing (wick)
259660	23253	Frame Oil Well Washer
225455	23253	Frame Spring
225456	23253	Frame Spring Plunger
225368	23253	Pulley with 200380C
200380C	23253	Pulley Set Screw
225381	23253	Spindle
225444	23253	Stop Latch
200056E	23253	Stop Latch Screw
225458	23253	Stop Latch Thumb Lever
225459	23253	Stop Latch Thumb Lever Hinge Stud
225459	23253	Stop Latch Thumb Lever Joint Stud
202478	23253	Stop Latch Trip Lever
200299B	23253	Stop Latch Trip Lever Hinge Screw
225461	23253	Tension Bracket with 201499B
200082D	23253	Tension Bracket Screw
228026	23253	Tension Bracket Screw Washer
2102	23253	Tension Disc (2)
13710	23253	Tension Spring
201499B	23253	Tension Stud
201572B	23253	Tension Stud Thumb Nut
225462	23253	Bobbin Winder Tension Bracket complete, Nos. 13710, 201572B, 225461 and two 2102
259431	23253	Bobbin Winder (round belt) complete, Nos. 200056E, 200082D, 200113F, 200299B, 202478, 225368, 225381, 225444, 225453, 225454, 225455, 225456, 225458, 225462, 228026, 259428, 259429, 259430 and two each 225459 and wood screws 3/4 in. No. 12 R. H. B.

CORDERS

CORDER

For Upholstery and Similar Work
for 1/8 in. to 1/2 in. Cord, in Steps of 1/32 in.

No.	Plate	Name
25784	24176	Cord Guide.....
25785	24176	Cord Guide Arm.....
101D	24176	Cord Guide Arm Hinge Screw.....
25783	24176	Cord Guide Bed.....
25786	24176	Cord Guide Dowel Pin.....
217J	24176	Cord Guide Screw.....
190J	24176	Cord Guide Screw (to bed of machine) (2).....
7071	24176	Cord Guide Screw Washer (2).....
25787	24176	Corder complete, Nos. 101D, 217J, 25783, 25784, 25785 and 25786.....
NOTE: When ordering No. 25787, furnish a finished sample or state size of cord.		
161282	24176	Feed Dog, for use with 17 teeth (16 teeth to the inch).....
120369	24176	Feeding Foot.....
120370	24176	Lifting Presser Foot.....
161283	24176	Throat Plate.....

CORDER (ADJUSTABLE)

For Upholstery and Similar Work
for 1/8 in. to 1/2 in. Cord, in Steps of 1/32 in.

No.	Plate	Name
26795	24177	Cord Guide.....
26796	24177	Cord Guide Arm with 26798 and three 6037.....
1044D	24177	Cord Guide Arm Hinge Screw.....
28644	24177	Cord Guide Bed.....
26798	24177	Cord Guide Bracket.....
6037	-----	Cord Guide Bracket Pin (3).....
190J	24177	Cord Guide Screw.....
190J	24177	Cord Guide Screw (to bed of machine) (2).....
7071	24177	Cord Guide Screw Washer (2).....
28645	24177	Corder (adjustable) complete, Nos. 190J, 1044D, 26795, 26796 and 28644.....
NOTE: When ordering No. 28645, furnish a finished sample or state size of cord.		
161282	24177	Feed Dog, 17 teeth (16 teeth to the inch).....
120369	24177	Feeding Foot.....
120370	24177	Lifting Presser Foot.....
161283	24177	Throat Plate.....

CORDER

For Upholstery and Similar Work
for Short Turns, for 1/8 in. to 1/2 in. Cord, in Steps of 1/32 in.

No.	Plate	Name
26795	24178	Cord Guide.....
26796	24178	Cord Guide Arm with 26798 and three 6037.....
1044D	24178	Cord Guide Arm Hinge Screw.....
120206	24178	Cord Guide Bed with 457AL.....
457AL	24178	Cord Guide Bed Leveling Screw.....
26798	24178	Cord Guide Bracket.....
6037	-----	Cord Guide Bracket Pin (3).....
190J	24178	Cord Guide Screw.....
190J	24178	Cord Guide Screw (to bed of machine) (2).....
7071	24178	Cord Guide Screw Washer (2).....
120207	24178	Corder complete, Nos. 190J, 1044D, 26795, 26796 and 120206.....
NOTE: When ordering No. 120207, furnish a finished sample or state size of cord.		
161282	24178	Feed Dog, 17 teeth (16 teeth to the inch).....
120369	24178	Feeding Foot.....
120370	24178	Lifting Presser Foot.....
161283	24178	Throat Plate.....

EDGE FOLDER

EDGE FOLDER ON SHANK

For Broadcloth, Muslin and Similar Material,
for 1/8 in. to 5/8 in. Edge Fold, in steps of 1/16 in.

No.	Plate	Name
28649	24179	Edge Folder on Shank.....
NOTE: When ordering, furnish a finished sample or state size of edge fold.		
1443J	24179	Edge Folder Screw (to bed of machine) (2).....
35227	24179	Feed Dog, 20 teeth (16 teeth to the inch).....
35181	24179	Feeding Foot.....
36345	24179	Lifting Presser Foot.....
35229	24179	Throat Plate.....

EDGE FOLDER (TURN-UP) ON SHANK

For Muslin, Indian Head, Blue Denim, Dress Suit Material, etc. and Plastics,
for 1/4 in. to 3/4 in. Edge Folds, in steps of 1/16 in.

No.	Plate	Name
161181	24180	Edge Folder (turn up) on Shank with two 1443J, adjustable backward and forward as well as sidewise.....
NOTE: When ordering, furnish a finished sample or state size of edge fold.		
1443J	24180	Edge Folder Screw (2)
1443J	24180	Edge Folder Screw (to bed of machine) (2).....
35227	24180	Feed Dog, 20 teeth (16 teeth to the inch)...
35181	24180	Feeding Foot
36345	24180	Lifting Presser Foot
35229	24180	Throat Plate.....

FINGER GUARDS

No.	Plate	Name
121328	24181	Finger Guard (Narrow).....
121332	24181	Finger Guard (Wide)

FITTINGS

For Upholstery and Similar Work,
For Various Sizes of Cord

No.	Plate	Name
161282	24181	Feed Dog, 17 teeth (16 teeth to the inch)...
6319	24181	Feed (upper) Bar
56882	24181	Feeding Foot
56883	24181	Lifting Presser Foot
161283	24181	Throat Plate

HEMMERS

HEMMER ON SHANK

For Muslin and Similar Materials,
for 1/8 in. to 1/4 in. Hem, in steps of 1/16 in.

No.	Plate	Name
35227	24182	Feed Dog, 20 teeth (16 teeth to the inch)...
35181	24182	Feeding Foot
120991	24182	Hemmer on Shank for 1/8 in. to 1/4 in. hem in steps of 1/16 in.
NOTE: When ordering, furnish a finished sample or state size of hem.		

HEMMER ON SHANK

No.	Plate	Name
190J	24182	Hemmer Screw (to bed of machine) (2)....
7071	24182	Hemmer Screw Washer (2).....
121746	24182	Hemmer Shank Leveling Plate
36345	24182	Lifting Presser Foot
35229	24182	Throat Plate

HEMMER ON SHANK

For Chambray, Flannel, Indian Head, Blue Denim and Similar Materials,
for 1/8 in. to 3/4 in. Hem, in steps of 1/16 in.

No.	Plate	Name
35227	24183	Feed Dog, 20 teeth (16 teeth to the inch) ..
35181	24183	Feeding Foot
28627	24183	Hemmer on Shank for 1/8 in. to 3/4 in. hem, in steps of 1/16 in.
NOTE: When ordering, furnish a finished sample or state size of hem.		
190J	24183	Hemmer Screw (to bed of machine) (2)....
7071	24183	Hemmer Screw Washer (2).....
36345	24183	Lifting Presser Foot
35229	24183	Throat Plate

HEMMER ON SHANK

For Heavy Canton Flannel and Similar Materials,
for 3/16 in. to 5/8 in. Hem, in steps of 1/16 in.

No.	Plate	Name
35227	24184	Feed Dog, 20 teeth (16 teeth to the inch) ..
35181	24184	Feeding Foot
28650	24184	Hemmer on Shank for 3/16 in. to 5/8 in. hem, in steps of 1/16 in.
NOTE: When ordering, furnish a finished sample or state size of hem.		
190J	24184	Hemmer Screw (to bed of machine) (2)....
7071	24184	Hemmer Screw Washer (2).....
121746	24184	Hemmer Shank Leveling Plate
36345	24184	Lifting Presser Foot
35229	24184	Throat Plate

HEMMER ON SHANK

For Muslin and Similar Materials,
for 1/4 in. to 1/2 in. Hem, in steps of 1/16 in.

No.	Plate	Name
35227	24185	Feed Dog, 20 teeth (16 teeth to the inch)..
35181	24185	Feeding Foot
28719	24185	Hemmer on Shank for 1/4 in. to 1/2 in. hem, in steps of 1/16 in.
NOTE: When ordering, furnish a finished sample or state size of hem.		
1443J	24185	Hemmer Screw (to bed of machine) (2)...
36345	24185	Lifting Presser Foot
35229	24185	Throat Plate

HEMMER ON SHANK (TURN-UP) ADJUSTABLE
(Backwards and Forwards as well as Sidewise)
For Broadcloth, Muslin, Chambray, Plastic and Similar Materials,
for 1/4 in. to 5/8 in. Hem, in steps of 1/16 in.

No.	Plate	Name
35227	24186	Feed Dog, 20 teeth (16 teeth to the inch)..
35181	24186	Feeding Foot
161184	24186	Hemmer on Shank (turn up) Adjustable with two 1443J for 1/4 in. to 5/8 in. hem, in steps of 1/16 in.
NOTE: When ordering, furnish a finished sample or state size of hem.		
1443J	24186	Hemmer Screw (2)
190J	24186	Hemmer Screw (to bed of machine) (2)...
7071	24186	Hemmer Screw Washer (2)
121746	24186	Hemmer Shank Leveling Plate
36345	24186	Lifting Presser Foot
35229	24186	Throat Plate

HEMMER ON SHANK (ADJUSTABLE, HINGED)

For Bottoms of Pajamas and Shorts,
for 3/8 in. to 3/4 in. Hem, in steps of 1/16 in.

No.	Plate	Name
35227	24187	Feed Dog, 20 teeth (16 teeth to the inch)..
35181	24187	Feeding Foot
160325	24187	Hemmer on Shank
28972	24187	Hemmer Holder
35610	24187	Hemmer Holder Friction Washer
940W	24187	Hemmer Holder Hinge Screw
120427	24187	Hemmer Holder Shank
190J	24187	Hemmer Screw (to bed of machine) (2)...
7071	24187	Hemmer Screw Washer (2)

HEMMER ON SHANK (ADJUSTABLE, HINGED) 23

No.	Plate	Name
51224W	24187	Hemmer Thumb Screw
7071	24187	Hemmer Thumb Screw Washer
160326	24187	Hemmer on Shank (adjustable, hinged) complete, for 3/8 in. to 3/4 in. hem, in steps of 1/16 in., Nos. 940W, 7071, 28972, 35610, 51224W, 120427 and 160325
NOTE: When ordering furnish a finished sample or state size of hem.		
121746	24187	Hemmer Shank Leveling Plate
36345	24187	Lifting Presser Foot
35229	24187	Throat Plate

HEMMER ON SHANK (TURN-UP) ADJUSTABLE
(Backwards and Forwards as well as Sidewise)
For Huck Toweling and Similar Materials,
for 3/8 in. to 1 5/16 in. Hem, in steps of 1/16 in.

No.	Plate	Name
35227	24188	Feed Dog, 20 teeth (16 teeth to the inch)..
35181	24188	Feeding Foot
161044	24188	Hemmer on Shank (turn-up) Adjustable with two 1443J for 3/8 in. to 1-5/16 in. hem, in steps of 1/16 in.
NOTE: When ordering, furnish a finished sample or state size of hem.		
1443J	24188	Hemmer Screw (2)
190J	24188	Hemmer Screw (to bed of machine) (2)...
7071	24188	Hemmer Screw Washer (2)
121746	24188	Hemmer Shank Leveling Plate
36345	24188	Lifting Presser Foot
35229	24188	Throat Plate

HEMMER ON SHANK

For Muslin and Similar Materials,
for 7/16 in. to 1 1/8 in. Hem, in steps of 1/16 in.

No.	Plate	Name
35227	24189	Feed Dog, 20 teeth (16 teeth to the inch)..
35181	24189	Feeding Foot
35236	24189	Hemmer on Shank for 7/16 in. to 1-1/8 in. hem, in steps of 1/16 in.
NOTE: When ordering, furnish a finished sample or state size of hem.		
190J	24189	Hemmer Screw (to bed of machine) (2)...
7071	24189	Hemmer Screw Washer (2)
121746	24189	Hemmer Shank Leveling Plate
36345	24189	Lifting Presser Foot
35229	24189	Throat Plate

HEMMER ON SHANK

For Muslin and Similar Materials,
for 9/16 in. to 1 in. Hem, in steps of 1/16 in.

No.	Plate	Name
35227	24190	Deed Dog, 20 teeth (16 teeth to the inch)..
35181	24190	Feeding Foot
28720	24190	Hemmer on Shank for 9/16 in. to 1 in. hem, in steps of 1/16 in.
NOTE: When ordering, furnish a finished sample or state size of hem.		
190J	24190	Hemmer Screw (to bed of machine) (2) ..
7071	24190	Hemmer Screw Washer (2)
121746	24190	Hemmer Shank Leveling Plate
36345	24190	Lifting Presser Foot
35229	24190	Throat Plate

HEMMER ON SHANK

For Muslin and Similar Materials,
for 1 1/16 in. to 2 in. Hem, in steps of 1/16 in.

No.	Plate	Name
35227	24191	Feed Dog, 20 teeth (16 teeth to the inch)..
35181	24191	Feeding Foot
28721	24191	Hemmer on Shank for 1-1/16 in. to 2 in. hem, in steps of 1/16 in.
NOTE: When ordering, furnish a finished sample or state size of hem.		
190J	24191	Hemmer Screw (to bed of machine) (2) ..
7071	24191	Hemmer Screw Washer (2)
121746	24191	Hemmer Shank Leveling Plate
36345	24191	Lifting Presser Foot
35229	24191	Throat Plate

HEMMER ON SHANK

For Muslin and Similar Materials,
for 2 1/16 in. to 3 in. Hem, in steps of 1/16 in.

No.	Plate	Name
35227	24192	Feed Dog, 20 teeth (16 teeth to the inch)..
35181	24192	Feeding Foot
36776	24192	Hemmer on Shank for 2-1/16 in. to 3 in. hem, in steps of 1/16 in.
NOTE: When ordering, furnish a finished sample or state size of hem.		
190J	24192	Hemmer Screw (to bed of machine) (2) ..
7071	24192	Hemmer Screw Washer (2)
121746	24192	Hemmer Shank Leveling Plate
36345	24192	Lifting Presser Foot
35229	24192	Throat Plate

KNEE LIFTER PARTS

No.	Plate	Name
80657	24163	Bell Crank with 445C
445C	24163	Bell Crank Set Screw
12234	24163	Bell Crank Shaft
12235	24163	Bell Crank Spring
4894	24163	Lifting Lever with 448AL
4895	24163	Lifting Lever Connecting Rod
12416	24163	Lifting Lever Connecting Rod Joint
76D	24163	Lifting Lever Connecting Rod Joint Hinge Screw
1521E	24163	Lifting Lever Connecting Rod Lock Nut.
1064D	24163	Lifting Lever Hinge Screw
4896	24163	Lifting Lever Hook
448AL	24163	Lifting Lever Hook Set Screw
2763	22128	Rock Shaft
139633	----	Rock Shaft 2763 with 2770, 6337 and 139623.
7539	22128	Rock Shaft Hanger with two wood screws 1 in. No. 10 (2)
2765	22128	Rock Shaft Knee Arm with 1509E
2766	22128	Rock Shaft Knee Arm Hub with 356C
356C	22128	Rock Shaft Knee Arm Hub Set Screw
1509E	22128	Rock Shaft Knee Arm Lock Nut
2768	----	Rock Shaft Knee Arm complete, Nos. 2765, 2766 and 2767
2767	22128	Rock Shaft Knee Plate with 356C
356C	22128	Rock Shaft Knee Plate Set Screw
6337	22128	Rock Shaft Lifting Bracket with two 356C ..
139623	22128	Rock Shaft Lifting Bracket Hook
356C	22128	Rock Shaft Lifting Bracket Hook Set Screw.
356C	22128	Rock Shaft Lifting Bracket Set Screw
2770	22128	Rock Shaft Stop Dog with 140219C
140219C	----	Rock Shaft Stop Dog Set Screw
139625	22128	Rock Shaft complete, Nos. 2768, 139633 and two 7539
56902	----	Knee Lifter complete, Nos. 76D, 1064D, 1521E, 4725, 4726, 4894, 4895, 4896, 12234, 12235, 12416, 80657 and 139625

THREAD UNWINDER

FOR TWO SPOOLS

No.	Plate	Name
228764	24193	Spool Pin (2)
228766	24193	Spool Rest with 201254C
150203	24193	Spool Rest Cushion (felt) (2)
228767	24193	Spool Rest Rod
201254C	24193	Spool Rest Set Screw
228768	24193	Spool Stand
228769	24193	Thread Guide (2)
228770	24193	Thread Guide Holder
228774	24193	Thread Guide Rod

No.	Plate	Name
228776	24193	Thread Unwinder complete, for two spools Nos. 228766, 228767, 228768, 228770, 228774, two each 150203, 228764, 228769 and three wood screws 7/8 in. No. 12.....

**SINGER Needles should be used
in SINGER Machines**
**These Needles and their Containers
are marked with the
Company's Trademark "SIMANCO" 1**

**Needles in Containers marked
"FOR SINGER MACHINES"**
are NOT SINGER made needles 2

NUMERICAL LIST OF PARTS

No.	Plate	Name
35D	24175	Bobbin Winder Stop Latch Hinge Screw for 150788.....
46D	24175	Bobbin Winder Hinge Screw.....
76D	24163	Knee Lifter Lifting Lever Connecting Rod Joint Hinge Screw for 56902.....
89F	24164	Feed (upper) Bar Connecting Link Hinge Screw.....
101D	24176	Corder Cord Guide Arm Hinge Screw for 25787.....
123E	24160	Arm Screw.....
129D	24165	Feed (upper) Shaft Bracket (back) Screw for 4890.....
129D	24165	Feed (upper) Shaft Bracket (front) Screw for 4890.....
144D	24161	Arm Shaft Screw.....
145E	24161	Crank Connecting Rod Cap Screw for 4292.....
145B	24170	Shuttle Race Screw.....
155C	24167	Needle Bar Connecting Stud Set Screw for 15472.....
157E	24163	Feed (lower) Lifting Rock Shaft Crank Clamping Screw for 3166.....
157R	24163	Feed (lower) Rock Shaft Crank Set Screw for 29633.....
159D	24165	Feed (upper) Lever Bracket Screw (upper) for 4890.....
175D	24162	Face Plate Screw.....
180D	24165	Feed (upper) Lever Bracket Screw (lower) for 4890.....
190J	24172	Binder Screw (to bed of machine).....
190J	24176	Corder Cord Guide Screw (to bed of machine).....
190J	24177	Corder Cord Guide Screw for 28645 and 120207.....
190J	24182	Hemmer Screw (to bed of machine).....
196AL	24167	Needle Clamp Screw for 4265.....
208AL	24166	Feed Dog Screw.....
217J	24172	Binder Screw for 161286, 161287 and 161288.....
217J	24176	Corder Cord Guide Screw for 25787.....
217D	24166	Feeding Foot Screw.....
217D	24166	Lifting Presser Foot Screw.....
226J	24163	Oscillating Shaft Crank Slide Block Cap Screw for 15171.....
233J	24162	Face Plate Thread Guard Screw for 56873.....
233J	24171	Thread Take-up Spring Regulator Plate Adjusting Screw for 56873.....
237AL	24165	Feed (upper) Regulator Thumb Screw Stop Bracket Screw for 4938.....
262J	24168	Pressure Regulating Thumb Screw.....
284D	24166	Guide Thumb Screw.....
307C	24163	Feed (lower) Lifting Rock Shaft Screw Center for 56814.....

NUMERICAL LIST OF PARTS

No.	Plate	Name
307C	24163	Feed (lower) Rock Shaft Screw Center for 56814.....
313C	24163	Feed (lower) Bar Screw Center for 56813 .
356C	22128	Knee Lifter Rock Shaft Knee Arm Hub Set Screw for 2766
356C	22128	Knee Lifter Rock Shaft Knee Plate Set Screw for 2767
356C	22128	Knee Lifter Rock Shaft Lifting Bracket Hook Set Screw for 6337
356C	22128	Knee Lifter Rock Shaft Lifting Bracket Set Screw for 6337
375C	24161	Crank Connecting Rod Hinge Screw
375C	24161	Feed (lower) Connecting Link Hinge Screw for 5748
375C	24161	Feed (lower) Forked Connection Hinge Screw
390E	24167	Needle Bar Connecting Link Adjusting Screw for 4898
404J	24164	Guide Bar Lifting Bracket Screw for 4899 .
418E	24175	Bobbin Winder Tension Screw Stud for 27308.....
435AL	24161	Machine Pulley Set Screw for 56898.....
445C	24163	Knee Lifter Ball Crank Set Screw for 80657.....
448AL	24161	Feed (lower and upper) Cam Set Screw for 4745.....
448AL	24163	Knee Lifter Lifting Lever Hook Set Screw for 4894
448AL	24162	Tension Screw Stud Set Screw for 56873....
453AL	24165	Feed (upper) Forked Connection Set Screw for 4746
457AL	24178	Corder Cord Guide Bed Leveling Screw for 120206.....
460AL	24162	Thread Retaining Stud Set Screw for 56873.
462AL	24163	Oscillating Shaft Crank Set Screw for 15165
462AL	24163	Shuttle Driver Set Screw for 68752.....
591F	24169	Shuttle Tension Regulating Screw for 15277
592E	24169	Shuttle Bobbin Case Latch Stop Screw for 15277.....
598C	24168	Lifting Presser Bar Lifter Screw.....
600C	24171	Tension Screw Stud for 16202
620AL	24165	Feed (upper) Lever Hinge Pin Set Screw for 6305
635C	24161	Oscillating Rock Shaft Hinge Pin Screw Bearing for 15489.....
641E	24168	Lifting Presser Bar Bracket Clamping Screw for 3133
648J	24170	Shuttle Race Back Spring Screw for 56897 .
651D	24167	Needle Clamp Thread Guide Screw for 4865
662AL	24170	Shuttle Race Cap Screw for 15420.....
665J	24174	Lifting Presser Foot Spring Guide Screw for 36465
666F	24165	Feed (upper) Regulator Thumb Screw Lock Screw for 4938

NUMERICAL LIST OF PARTS

No.	Plate	Name
690E	24161	Guide Bar Driving Crank Wedge Screw for 5750.....
691AL	24166	Throat Plate Screw
810D	24164	Feed (upper) Bar Hinge Cap Screw for 4899
810E	24164	Lifting Presser Bar Lifting Bell Crank Hinge Cap Screw for 4899.....
818W	24161	Feed (lower) Regulator Thumb Screw for 56894
940W	24187	Hemmer Holder Hinge Screw for 160326....
1014D	24165	Feed (upper) Regulator Thumb Screw for 4938
1035C	24163	Oscillating Shaft Crank Slide Block Screw Stud for 15171.....
1044D	24177	Corder Cord Guide Arm Hinge Screw for 28645 and 120207
1064D	24163	Knee Lifter Lifting Lever Hinge Screw for 56902
1088C	24167	Thread Take-up Lever Hinge Screw for 56855
1443J	24179	Edge Folder Screw (to bed of machine)....
1443J	24180	Edge Folder Screw for 161181.....
1443J	24185	Hemmer Screw (to bed of machine).....
1443J	24186	Hemmer Screw for 161044 and 161184.....
1509E	22128	Knee Lifter Rock Shaft Knee Arm Lock Nut for 2765
1513J	24163	Feed (lower) Lifting Rock Shaft Screw Center Nut for 56814
1513J	24163	Feed (lower) Rock Shaft Screw Center Nut for 56814
1513J	24161	Oscillating Rock Shaft Hinge Pin Nut for 56812.....
1513J	24161	Oscillating Rock Shaft Hinge Pin Screw Bearing Nut for 15489
1518J	24161	Crank Connecting Rod Hinge Screw Nut....
1518J	24161	Feed (lower) Connecting Link Hinge Screw Nut for 5748
1518J	24161	Feed (lower) Forked Connection Hinge Screw Nut
1519J	24163	Feed (lower) Bar Screw Center Nut for 56813.....
1519E	24163	Oscillating Shaft Crank Slide Block Screw Stud Nut for 15165
1521E	24163	Knee Lifter Lifting Lever Connecting Rod Lock Nut for 56902.....
1560C	24171	Tension Regulating Thumb Nut for 16202 ..
1562J	24175	Bobbin Winder Tension Regulating Thumb Nut for 27308.....
1620J	24175	Bobbin Winder Frame Hinge Screw Nut for 150788
1632C	24168	Pressure Regulating Thumb Screw Lock Nut.....
1813	----	Feed (lower) Lifting Rock Shaft Crank Roller and Stud Nos. 1904 and 125060 for 3166

No.	Plate	Name
1819	24167	Thread Take-up Lever Roller and Stud for 3072.....
1823	24168	Lifting Presser Bar Bracket Roller and Stud for 3133.....
1862	24167	Guide Bar Driving Crank Roller (roller only) for 4854.....
1904	24163	Feed (lower) Lifting Rock Shaft Crank Roller for 1813.....
2002	24160	Arm Dowel Pin.....
2049	24165	Feed (upper) Regulator Pin for 56774.....
2058	24168	Lifting Presser Bar.....
2070	24168	Lifting Presser Bar Spring Washer.....
2102	23253	Bobbin Winder Tension Disc for 225462.....
2102	24171	Tension Disc for 56791.....
2103	24171	Tension Spring for 56791.....
2105	24162	Tension Thread Guard for 56872.....
2106	24175	Bobbin Winder Tension Thread Guard for 27308.....
2111	24171	Thread Retainer Guide complete, for 56873, Nos. 2112, 2114 and 2115.....
2112	24171	Thread Retaining Disc with 2113 for 2111.....
2113	24171	Thread Retaining Disc Steady Pin for 2112.....
2114	24171	Thread Retaining Spring for 2111.....
2115	24171	Thread Retaining Stud for 2111.....
2124	24171	Thread Take-up Spring for 56791.....
2127	24171	Thread Take-up Spring Regulator Spring for 56873.....
2269	24162	Tension Releaser Hinge Pin for 56873.....
2361	24164	Feed (upper) Bar Hinge Bracket for 56752.....
2362	24164	Feed (upper) Bar Hinge Bracket Rivet for 56752.....
2455	24175	Bobbin Winder Tension Disc for 27308.....
2460	24175	Bobbin Winder Friction Ring (rubber) for 5528.....
2461	24175	Bobbin Winder Pulley for 5530.....
2464	24175	Bobbin Winder Spring.....
2515	24169	Shuttle Body for 15100.....
2530	24170	Shuttle Race Body for 15420.....
2531	24170	Shuttle Race Back for 56897.....
2532	24170	Shuttle Race Back Position Pin for 56897.....
2533	24170	Shuttle Race Back Spring for 56897.....
2535	24170	Shuttle Race Cap for 15420.....
2763	22128	Knee Lifter Rock Shaft for 139633.....
2765	22128	Knee Lifter Rock Shaft Knee Arm with 1509E for 2768.....
2766	22128	Knee Lifter Rock Shaft Knee Arm Hub with 356C for 2768.....
2767	22128	Knee Lifter Rock Shaft Knee Plate with 356C for 2768.....
2768	-----	Knee Lifter Rock Shaft Knee Arm complete, for 139625, Nos. 2765, 2766 and 2767.....
2770	22128	Knee Lifter Rock Shaft Stop Dog with 140219C for 139633.....
2824	24160	Shuttle Race Slide Spring for 80528.....

No.	Plate	Name
2973	24169	Shuttle Bobbin Case Latch Lever for 15141.....
2974	24169	Shuttle Bobbin Case Latch Lever Fulcrum Pin for 15141.....
2975	24169	Shuttle Bobbin Case Latch Spring for 15277.....
2996	24169	Shuttle Bobbin for 15100.....
3005	24161	Arm Shaft Bushing (back).....
3012	24161	Thread Take-up Cam Pin.....
3037	24161	Feed (lower) Forked Connection for 5748.....
3042	24163	Feed (lower) Rock Shaft for 56880.....
3052	24161	Oscillating Rock Shaft Hinge Pin for 56812.....
3072	24167	Thread Take-up Lever with 1819 for 56855.....
3093	24165	Feed (upper) Forked Connection Pin.....
3094	-----	Guide Bar Driving Crank Wedge for 5750.....
3100	-----	Lifting Presser Bar Spring (heavy).....
3126	24164	Guide Bar for 56752.....
3131	24167	Guide Bar Driving Crank Roller Cap for 4854.....
3133	24168	Lifting Presser Bar Bracket with 641E and 1823.....
3163	-----	Feed (lower) Lifting Rock Shaft complete, Nos. 3165 and 3166.....
3165	24163	Feed (lower) Lifting Rock Shaft for 3163.....
3166	24163	Feed (lower) Lifting Rock Shaft Crank with 157E and 1813 for 3163.....
3168	24163	Oscillating Shaft.....
4264	24167	Needle Bar.....
4265	24167	Needle Clamp with 196AL for 4865.....
4266	24167	Needle Clamp Thread Guide for 4865.....
4292	24161	Crank Connecting Rod with 125044 and two 145E.....
4304	24161	Oscillating Rock Shaft (steel) with 4784 for 5747.....
4305	24160	Shuttle Race Slide for 80528.....
4347	24153	Wrench for 1513 and 1518 (accessories).....
4359	24161	Arm Shaft for 56811.....
4378	24161	Tension Releaser for 56873.....
4391	24163	Feed (lower) Bar.....
4448	24160	Arm Oil Tube for intermediate bearing for 4890.....
4449	24161	Arm Shaft Bushing (front) for 4890.....
4642	24166	Feed Dog 15 teeth (16 teeth to the inch).....
4646	24166	Throat Plate, large needle hole.....
		NOTE: No. 4646 is regularly furnished with this machine.
4723	24164	Guide Bar Lifting Bracket for 4899.....
4725	24168	Lifting Presser Bar Lifting Bracket for 56902.....
4726	24168	Lifting Presser Bar Lifting Bracket Guide Pin for 56902.....
4743	24160	Arm Side Cover.....
4744	24164	Feed (upper) Bar for 4899.....
4745	24161	Feed (upper and lower) Cam with 448AL for 56811.....

NUMERICAL LIST OF PARTS

No.	Plate	Name
4746	24165	Feed (upper) Forked Connection with 453AL for 56774.
4747	24161	Feed (lower) Regulator for 56894.
4784	24161	Oscillating Rock Shaft Oil Pad for 4304.
4854	24167	Guide Bar Driving Crank with 1862 and 3131.
4865	24167	Needle Clamp complete, Nos. 651D, 4265 and 4266.
* 4890	-----	Arm with 159D, 180D, 4448, 4449, 4891, 4892, 6305 and four 129D.
4891	24165	Feed (upper) Shaft Bracket (front) for 4890.
4892	24165	Feed (upper) Shaft Bracket (back) for 4890.
4894	24163	Knee Lifter Lifting Lever with 448AL for 56902.
4895	24163	Knee Lifter Lifting Lever Connecting Rod for 56902.
4896	24163	Knee Lifter Lifting Lever Hook for 56902.
4897	24164	Lifting Presser Bar Lifting Bell Crank for 4899.
4898	24167	Needle Bar Connecting Link with 390E for 56764.
4899	-----	Guide Bar complete, Nos. 810D, 810E, 4723, 4744, 4897, 56752 and three 404J.
4904	24165	Feed (upper) Lever.
4907	24165	Feed (upper) Regulator Thumb Screw Stop Bracket for 4938.
4908	24165	Feed (upper) Shaft for 56774.
4909	24168	Lifting Presser Bar Lifter.
4918	-----	Wrench for 1632 (accessories).
4938	-----	Feed (upper) Regulator complete, for 56774, Nos. 666F, 1014D, 4907, 4959, 13076, 56904 and two 237AL.
4959	24165	Feed (upper) Regulator Thumb Screw Lock Stud (brass) for 4938.
5522	24175	Bobbin Winder Frame for 5528.
5528	24175	Bobbin Winder (tight wheel) complete, Nos. 2460, 5522 and 5530.
5529	24175	Bobbin Winder Spindle for 5530.
5530	-----	Bobbin Winder Spindle 5529 with 2461 for 5528.
5747	-----	Oscillating Rock Shaft 4304 with 15489 and 56812.
5748	-----	Feed (lower) Forked Connection complete, Nos. 3037, 52165, 56894 and two each 375C and 1518J.
5750	-----	Guide Bar Driving Crank Wedge 3094 with 690E.
5792	24166	Lifting Presser Foot.
6037	-----	Corder Cord Guide Bracket Pin for 26796.
* 6305	-----	Feed (upper) Lever Bracket with two 620AL for 4890.
6306	24164	Feed (upper) Bar Connecting Link.

NUMERICAL LIST OF PARTS

No.	Plate	Name
6307	24165	Feed (upper) Lever Hinge Pin.
6319	24181	Feed (upper) Bar for upholstery and similar work, for various sizes of cord.
6337	22128	Knee Lifter Rock Shaft Lifting Bracket with two 356C for 139633.
7071	24172	Binder Screw Washer (to bed of machine).
7071	24172	Binder Screw Washer for 161286, 161287 and 161288.
7071	24176	Corder Cord Guide Screw Washer.
7071	24182	Hemmer Screw Washer.
7071	24187	Hemmer Thumb Screw Washer for 160326.
7539	22128	Knee Lifter Rock Shaft Hanger with two wood screws 1 in. No. 10 for 139625.
8225	-----	Lifting Presser Bar Spring (extra heavy).
8879	24160	Arm Spool Pin Washer (cloth).
8908	24153	NOTE: When ordering No. 8879, state color required.
10141	24175	Wrench for 1519 and 1520 (accessories).
11241	24175	Bobbin Winder Tension Spring for 27308.
12234	24175	Bobbin Winder Spool Washer (cloth) for 27308.
12235	24163	Knee Lifter Bell Crank Shaft for 56902.
12361	24163	Knee Lifter Bell Crank Spring for 56902.
12416	24153	Machine Hinge Connection.
12424	24163	Knee Lifter Lifting Lever Connecting Rod Joint for 56902.
13076	24163	Oscillating Shaft Crank Slide Block Cap Screw Washer for 15171.
13710	24165	Feed (upper) Regulator Slide Block for 4938.
15072	23253	Bobbin Winder Tension Spring for 225462.
15100	24175	Bobbin Winder Bobbin Position Pin for 27538.
15140	24169	Shuttle, 1-11/16 in. diam., Nos. 2515, 2996 and 15277.
15141	24169	Shuttle Bobbin Case Latch for 15141.
15165	-----	Shuttle Bobbin Case Hinge with 2973, 2974 and 15140 for 15277.
15170	24163	Oscillating Shaft Crank complete, Nos. 1519E, 15171, 15426 and two 462AL.
15171	24163	Oscillating Shaft Crank Slide Block for 15171.
15277	-----	Oscillating Shaft Crank Slide Block complete, for 15165, Nos. 226J, 1035C, 12424 and 15170.
15278	24169	Shuttle Bobbin Case with 591F, 592E, 2975, 15141 and 15278 for 15100.
15420	24169	Shuttle Tension Spring for 15277.
15426	-----	Shuttle Race Body 2530 with 2535 and two 662AL for 56897.
15472	24163	Oscillating Shaft Crank for 15165.
15489	24167	Needle Bar Connecting Stud with 155C for 56764.
15489	-----	Oscillating Rock Shaft Hinge Pin Screw Bearing 635C with 1513J for 5747.

No.	Plate	Name
16202	----	Tension Screw Stud 600C with 1560C for 56791.....
25783	24176	Corder Cord Guide Bed for 25787.....
25784	24176	Corder Cord Guide for 25787.....
25785	24176	Corder Cord Guide Arm for 25787.....
25786	24176	Corder Cord Guide Dowel Pin for 25787....
25787	24176	Corder complete, for upholstery and similar work for 1/8 in. to 1/2 in. cord, in steps of 1/32 in., Nos. 101D, 217J, 25783, 25784, 25785 and 25786.....
		NOTE: When ordering No. 25787, furnish a finished sample or state size of cord.
25875	24166	Guide.....
26026	24153	Screw Driver (machine) accessories.....
26485	24153	Screw Driver (shuttle tension) accessories.....
26795	24177	Corder Cord Guide for 28645 and 120207..
26796	24177	Corder Cord Guide Arm with 26798 and three 6037 for 28645 and 120207.....
26798	24177	Corder Cord Guide Bracket for 26796 and 120207.....
27136	24153	Machine Button with wood screws 1-1/2 in. No. 14 R. H. B. (accessories).....
27302	24175	Bobbin Winder Frame for 150788.....
27303	----	Bobbin Winder Frame Spring for 150788....
27306	24175	Bobbin Winder Spool Pin for 27308.....
27307	24175	Bobbin Winder Spool Stand for 27308.....
27308	24175	Bobbin Winder Spool Stand complete, for 150789, Nos. 418E, 1562J, 2106, 10141, 11241, 27306, 27307 and two each 2455 and wood screws 1 in. No. 10.....
27312	24175	Bobbin Winder Stop Latch for 150788.....
27538	24175	Bobbin Winder Spindle with 15072 and 41828 for 150788.....
27540	24175	Bobbin Winder Base for 150788.....
28627	24183	Hemmer on Shank for Chambray, Flannel, Indian Head, Blue Denim and similar material, for 1/8 in. to 3/4 in. hem, in steps of 1/16 in.
		NOTE: When ordering, furnish a finished sample or state size of hem.
28644	24177	Corder Cord Guide Bed for 28645.....
28645	24177	Corder (adjustable) complete, for upholstery and similar work for 1/8 in. to 1/2 in. cord in steps of 1/32 in., Nos. 190J, 1044D, 26795, 26796 and 28644.....
		NOTE: When ordering No. 28645, furnish a finished sample or state size of cord.
28649	24179	Edge Folder on Shank for Broadcloth, Muslin and similar material for 1/8 in. to 5/8 in. edge fold, in steps of 1/16 in.
		NOTE: When ordering, furnish a finished sample or state size of edge fold.

No.	Plate	Name
28650	24184	Hemmer on Shank for heavy Canton Flannel and similar materials for 3/16 in. to 5/8 in. hem, in steps of 1/16 in.
		NOTE: When ordering, furnish a finished sample or state size of hem.
28719	24185	Hemmer on Shank for Muslin and similar materials for 1/4 in. to 1/2 in. hem, in steps of 1/16 in.
		NOTE: When ordering, furnish a finished sample or state size of hem.
28720	24190	Hemmer on Shank for Muslin and similar materials for 9/16 in. to 1 in. hem, in steps of 1/16 in.
		NOTE: When ordering, furnish a finished sample or state size of hem.
28721	24191	Hemmer on Shank for Muslin and similar materials for 1-1/16 in. to 2 in. hem, in steps of 1/16 in.
		NOTE: When ordering, furnish a finished sample or state size of hem.
28972	24187	Hemmer Holder for 160326.....
29633	24163	Feed (lower) Rock Shaft Crank with 157R for 56880.....
32675	----	Lifting Presser Bar Spring (light).....
35181	24172	Feeding Foot for use with 28627, 28649, 28650, 28719, 28720, 28721, 35236, 36776, 120991, 160326, 161044, 161181, 161184, 161286 and 161287.....
35227	24172	Feed Dog, 20 teeth (16 teeth to the inch) for use with 28627, 28649, 28650, 28719, 28720, 28721, 35236, 36776, 120991, 160326, 161044, 161181, 161184, 161286 and 161287.....
35229	24172	Throat Plate for use with 28627, 28649, 28650, 28719, 28720, 28721, 35236, 36776, 120991, 160326, 161044, 161181, 161184, 161286, 161287 and 161288.....
35230	24172	Lifting Presser Foot for use with 161286 and 161287.....
35236	24189	Hemmer on Shank for Muslin and similar materials for 7/16 in. to 1-1/8 in. hem, in steps of 1/16 in.
		NOTE: When ordering, furnish a finished sample or state size of hem.
35610	24187	Hemmer Holder Friction Washer for 160326.....
36345	24179	Lifting Presser Foot for use with 28627, 28649, 28650, 28719, 28720, 28721, 35236, 36776, 120991, 160326, 161044, 161181 and 161184.....
36346	24174	Feeding Foot for use with 161288.....
36464	24174	Lifting Presser Foot Spring Guide for 36465.....

No.	Plate	Name
36465	24174	Lifting Presser Foot (right hand spring guide) 160942 with 665J and 36464, for use with 161288.
36776	24192	Hemmer on Shank for Muslin and similar materials, for 2-1/16 in. to 3 in. hem, in steps of 1/16 in.
		NOTE: When ordering, furnish a finished sample or state size of hem.
41400	24153	Machine Rest Pin (wood) accessories.
41828	24175	Bobbin Winder Spindle Collar Pin for 27538.
50356D	24175	Bobbin Winder Frame Hinge Screw for 150788.
51224W	24160	Arm Side Cover Thumb Screw.
51224W	24187	Hemmer Thumb Screw for 160326.
51282E	24160	Shuttle Race Slide Spring Screw for 80528.
52165	24161	Feed (lower) Connecting Link for 5748.
52239	24160	Arm Spool Pin and Thread Eyelet.
56752	-----	Guide Bar 3126 with 2361 and two 2362 for 4899.
56764	-----	Needle Bar Connecting Link 4898 with 15472.
56774	-----	Feed (upper) Shaft 4908 with 2049, 4746 and 4938.
56791	24171	Tension complete, for 56873, Nos. 2103, 2124, 16202 and two 2102.
56811	-----	Arm Shaft 4359 with 4745 and 56829.
56812	-----	Oscillating Rock Shaft Hinge Pin 3052 with 1513J for 5747.
56813	-----	Feed (lower) Bar Screw Center 313C with 1519J.
56814	-----	Feed (lower) Lifting Rock Shaft Screw Center 307C with 1513J.
56814	-----	Feed (lower) Rock Shaft Screw Center 307C with 1513J.
56829	24161	Thread Take-up Cam (steel) for 56811.
56836	-----	Throat Plate, small needle hole.
56845	-----	Feed Dog (spiked teeth).
56855	-----	Thread Take-up Lever 3072 with 1088C.
56870	24162	Face Plate Thread Guard for 56873.
56871	24162	Face Plate for 56872.
56872	-----	Face Plate 56871 with 2105 for 56873.
56873	-----	Face Plate complete, Nos. 448AL, 460AL, 2111, 2127, 2269, 4378, 56791, 56870, 56872 and two 233J.
56880	-----	Feed (lower) Rock Shaft complete, Nos. 3042 and 29633.
56882	24181	Feeding Foot for upholstery and similar work for various sizes of cord.
56883	24181	Lifting Presser Foot for upholstery and similar work for various sizes of cord.
56894	-----	Feed (lower) Regulator 4747 with 818W for 5748.
56896	24166	Feeding Foot.

No.	Plate	Name
56897	24170	Shuttle Race complete, Nos. 648J, 2531, 2533, 15420 and two 2532.
56898	24161	Machine Pulley (heavy rim) "V" Belt Groove (outside diam. of Belt Groove 2.9 in.) with two 435AL.
56902	-----	Knee Lifter complete, Nos. 76D, 1064D, 1521E, 4725, 4726, 4894, 4895, 4896, 12234, 12235, 12416, 80657 and 139625.
56903	24168	Lifting Presser Bar Spring.
		NOTE: No. 56903 is regularly furnished.
56904	24165	Feed (upper) Regulator for 4938.
68752	24163	Shuttle Driver with two 462AL.
80528	24160	Shuttle Race Slide complete, Nos. 2824, 4305 and two 51282E.
80657	24163	Knee Lifter Bell Crank with 445C for 56902.
* 80982	-----	Bed.
120206	24178	Corder Cord Guide Bed with 457AL for 120207.
120207	24178	Corder complete for upholstery and similar work for short turns, for 1/8 in. to 1/2 in. Cord, in steps of 1/32 in., Nos. 190J, 1044D, 26795, 26796 and 120206.
		NOTE: When ordering No. 120207, furnish a finished sample or state size of cord.
120342	24153	Oiler (copper plated) with 120343 (accessories).
120343	24153	Oiler Spout, 3-1/2 in. long for 120342.
120369	24176	Feeding Foot for use with 25787, 28645 and 120207.
120370	24176	Lifting Presser Foot for use with 25787, 28645 and 120207.
120427	24187	Hemmer Holder Shank for 160326.
120991	24182	Hemmer on Shank for Muslin and similar materials, for 1/8 in. to 1/4 in. hem, in steps of 1/16 in.
		NOTE: When ordering, furnish a finished sample or state size of hem.
121328	24181	Finger Guard (narrow).
121332	24181	Finger Guide (wide).
121746	24172	Binder Shank Leveling Plate, for use with 161286, 161287 and 161288.
121746	24182	Hemmer Shank Leveling Plate for use with 28650, 28720, 28721, 35236, 36776, 120991, 160326, 161044 and 161184.
125044	24161	Crank Connecting Rod Oil Pad (felt) for 4292.
125060	24163	Feed (lower) Lifting Rock Shaft Crank Roller Stud for 1813.
139603	24161	Feed (lower) Regulator Hinge Screen Friction Washer.
139623	22128	Knee Lifter Rock Shaft Lifting Bracket Hook for 139633.
139625	22128	Knee Lifter Rock Shaft complete, for 56902, Nos. 2768, 139633 and two 7539.

NUMERICAL LIST OF PARTS

No.	Plate	Name
139633	-----	Knee Lifter Rock Shaft 2763 with 2770, 6337 and 139623 for 139625.....
139637	-----	Drip Pan with four 1 in. wire nails.....
140139E	24161	Feed (lower) Regulator Hinge Screw
140219C	-----	Knee Lifter Rock Shaft Stop Dog Set Screw for 2770
140732AL	24161	Arm Shaft Bushing (back) Set Screw.....
150203	24193	Thread Unwinder Spool Rest Cushion (felt) for 228776
150785	24175	Bobbin Winder Pulley for 150788.....
150788	24175	Bobbin Winder, Nos. 35D, 1620J, 2730Z, 27303, 2731Z, 27538, 27540, 50356D, 150785 and two wood screws 1 in. No. 7 F. H. for 150789
150789	24175	Bobbin Winder (swinging automatic, right hand) complete, "V" belt drive, Nos. 27308 and 150788.....
160325	24187	Hemmer on Shank for 160326.....
160326	24187	Hemmer on Shank (adjustable, hinged) complete, for bottoms of pajamas and shorts, for 3/8 in. to 3/4 in. hem, in steps of 1/16 in., Nos. 940W, 7071, 28972, 35610, 51224W, 120427 and 160325
		NOTE: When ordering, furnish a finished sample or state size of hem.
160942	24174	Lifting Presser Foot for 36465
161044	24188	Hemmer on Shank (turn up) Adjustable with two 1443J (backward and forward, as well as sidewise for Huck Toweling and similar materials for 3/8 in. to 1-5/16 in. hem, in steps of 1/16 in.
		NOTE: When ordering, furnish a finished sample or state size of hem.
161181	24180	Edge Folder (turn up) on Shank with two 1443J adjustable backward as well as sidewise, for Muslin, Indian Head, Blue Denim, Dress Suit Material etc. and Plastics for 1/4 in. to 3/4 in. edge folds, in steps of 1/16 in.
		NOTE: When ordering, furnish a finished sample or state size of edge fold.
161184	24186	Hemmer on Shank (turn up) Adjustable with two 1443J (backward and forward as well as sidewise) for Broadcloth, Muslin, Chambray, Plastic and similar material for 1/4 in. to 5/8 in. hem, in steps of 1/16 in.
		NOTE: When ordering, furnish a finished sample or state size of hem.
161282	24176	Feed Dog, 17 teeth (16 teeth to the inch) for use with 25787, 28645, 120207 and for Fittings, for various sizes of cord..
161283	24176	Throat Plate for use with 25787, 28645, 120207 and for Fittings, for various sizes of cord.

NUMERICAL LIST OF PARTS

No.	Plate	Name
161286	24172	Binder on Shank with two each 217J and 7071, Adjustable backward and forward as well as sidewise for general, plastic, plastic coated as well as prefolded bias binding, for 7/16 in. to 3/4 in. binding, in steps of 1/16 in.
		NOTE: When ordering, furnish a finished sample and materials for testing or state size of binding or tape.
161287	24173	Binder on Shank with two each 217J and 7071, Adjustable backward and forward as well as sidewise for general, plastic, plastic coated tapes as well as prefolded bias binding, for 13/16 in. to 1-3/8 in. binding, in steps of 1/16 in.
		NOTE: When ordering, furnish a finished sample and materials for testing or state size of binding or tape.
161288	24174	Binder on Shank with two each 217J and 7071, Adjustable backward and forward as well as sidewise (Turn in top only) for general, plastic and plastic coated bindings for 1 in. to 1-3/4 in. bindings, in steps of 1/16 in.
		NOTE: When ordering, furnish a finished sample and materials for testing or state size of binding as well as size of finish.
161289	24174	Feed Dog (spiked teeth) for use with 161288
200056E	23253	Bobbin Winder Stop Latch Screw for 259431 and 259462.....
200082D	23253	Bobbin Winder Tension Bracket Screw for 259431 and 259462.....
200113F	23253	Bobbin Winder Brake Clamp Screw for 259431 and 259462.....
200299B	23253	Bobbin Winder Stop Latch Trip Lever Hinge Screw for 259431 and 259462.....
200380C	23253	Bobbin Winder Pulley Set Screw for 225368 and 259461.....
201254C	24193	Thread Unwinder Spool Rest Set Screw for 228766
201499B	23253	Bobbin Winder Tension Stud for 225461....
201572B	23253	Bobbin Winder Tension Stud Thumb Nut for 225462
202277	23253	Bobbin Winder Frame Oil Packing (wick) for 225453
202478	23253	Bobbin Winder Stop Latch Trip Lever for 259431 and 259462.....
225368	23253	Bobbin Winder Pulley with 200380C for 259431
225381	23253	Bobbin Winder Spindle for 259431 and 259462.....
225444	23253	Bobbin Winder Stop Latch for 259431 and 259462

NUMERICAL LIST OF PARTS

No.	Plate	Name
225453	23253	Bobbin Winder Frame with 202277 and 259460 for 259431 and 259462.....
225454	23253	Bobbin Winder Frame Hinge Pin for 259431 and 259462.....
225455	23253	Bobbin Winder Frame Spring for 259431 and 259462.....
225456	23253	Bobbin Winder Frame Spring Plunger for 259431 and 259462.....
225458	23253	Bobbin Winder Stop Thumb Lever for 259431 and 259462.....
225459	23253	Bobbin Winder Stop Latch Thumb Lever Hinge Stud for 259431 and 259462.....
225459	23253	Bobbin Winder Stop Latch Thumb Lever Joint Stud for 259431 and 259462.....
225461	23253	Bobbin Winder Tension Bracket with 201499B for 225462.....
225462	23253	Bobbin Winder Tension Bracket complete, for 259431 and 259462, Nos. 13710, 201572B, 225461 and two 2102.....
228026	23253	Bobbin Winder Tension Bracket Screw Washer for 259431 and 259462.....
228764	24193	Thread Unwinder Spool Pin for 228776.....
228766	24193	Thread Unwinder Spool Rest with 201254C, for 228776.....
228767	24193	Thread Unwinder Spool Rest Rod for 228776.....
228768	24193	Thread Unwinder Spool Stand for 228776.....
228769	24193	Thread Unwinder Thread Guide for 228776.....
228770	24193	Thread Unwinder Thread Guide Holder for 228776.....
228774	24193	Thread Unwinder Thread Guide Rod for 228776.....
228776	24193	Thread Unwinder complete, (for two spools) Nos. 228766, 228767, 228768, 228770, 228774, two each 150203, 228764, 228769 and three wood screws 7/8 in. No. 12.....
259428	23253	Bobbin Winder Brake (leather) for 259431 and 259462.....
259429	23253	Bobbin Winder Brake Clamp for 259431 and 259462.....
259430	23253	Bobbin Winder and Tension Bracket Base for 259431.....
259431	23253	Bobbin Winder (round belt) complete, Nos. 200056E, 200082D, 200113F, 200299B, 202478, 225368, 225381, 225444, 225453, 225454, 225455, 225456, 225458, 225462, 228026, 259428, 259429, 259430 and two each 225459 and wood screws 3/4 in. No. 12 R, H, B.....
259461	23253	Bobbin Winder Pulley with 200380C for 259462.....

NUMERICAL LIST OF PARTS

No.	Plate	Name
259462	23253	Bobbin Winder (Swinging Automatic right hand) complete for Power Table "V" belt drive, Nos. 200056E, 200082D, 200113F, 200299B, 202478, 225381, 225444, 225453, 225454, 225455, 225456, 225458, 225462, 228026, 259428, 259429, 259461, 259462 and two each 225459 and wood screws 3/4 in. No. 12 R, H.....
259660	23253	Bobbin Winder Frame Oil Well Washer for 225453.....
259662	23253	Bobbin Winder and Tension Bracket Base for 25462.....

SINGER Needles should be used
in **SINGER** Machines
These Needles and their Containers
are marked with the
Company's Trademark "**SIMANCO**" 1

Needles in Containers marked
"**FOR SINGER MACHINES**"
are **NOT** **SINGER** made needles 2

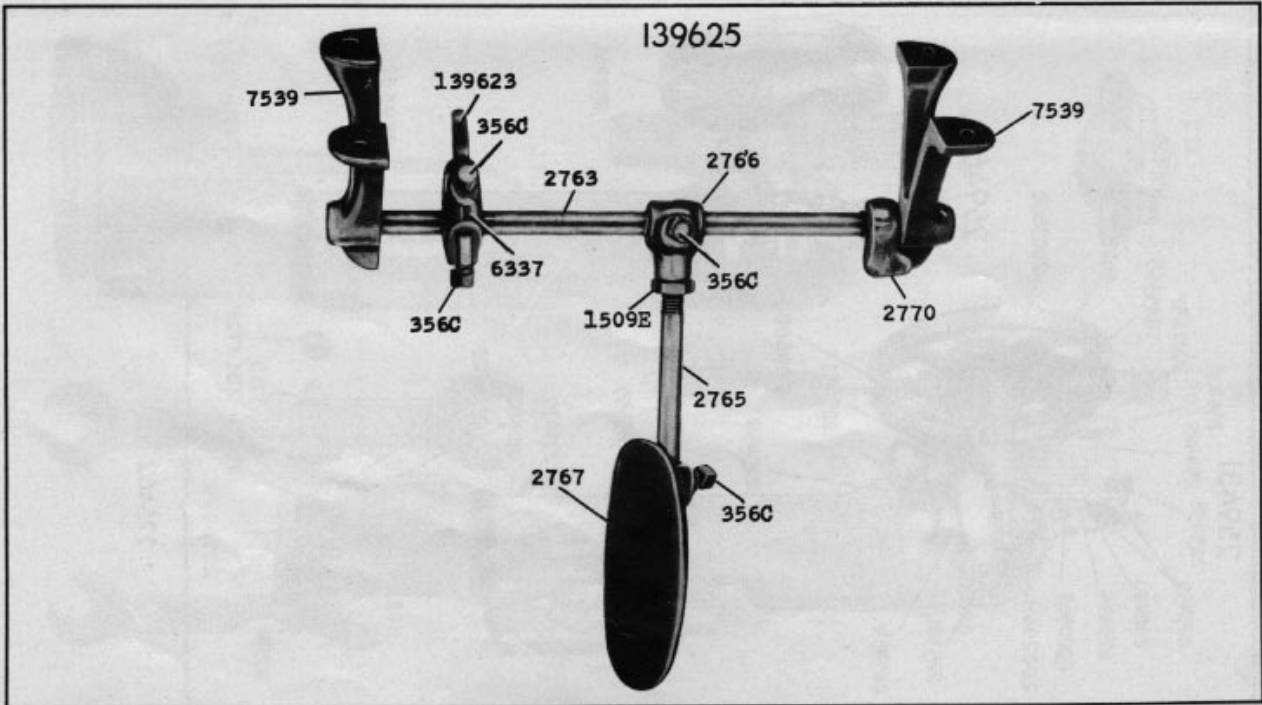

22128-1/3

23253 - 3/8

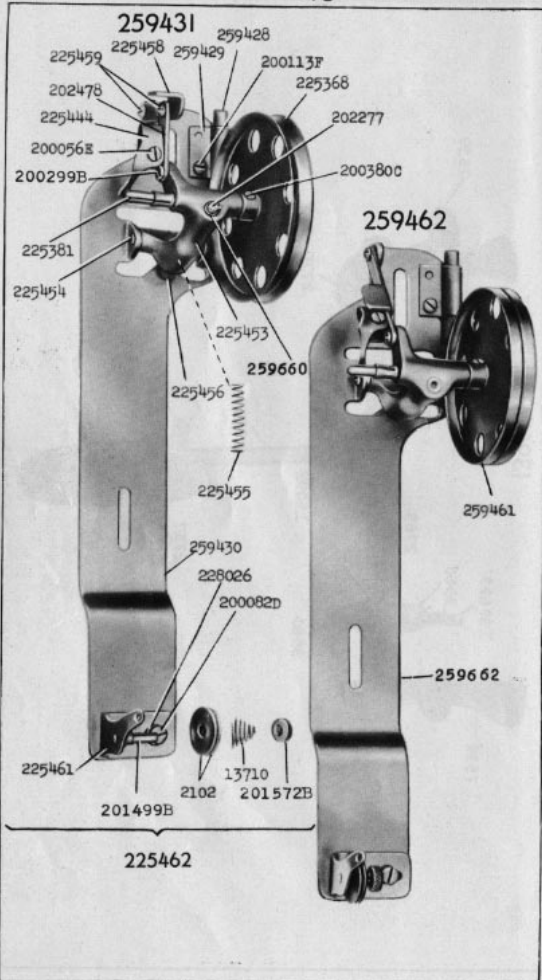

24153 - 1/2

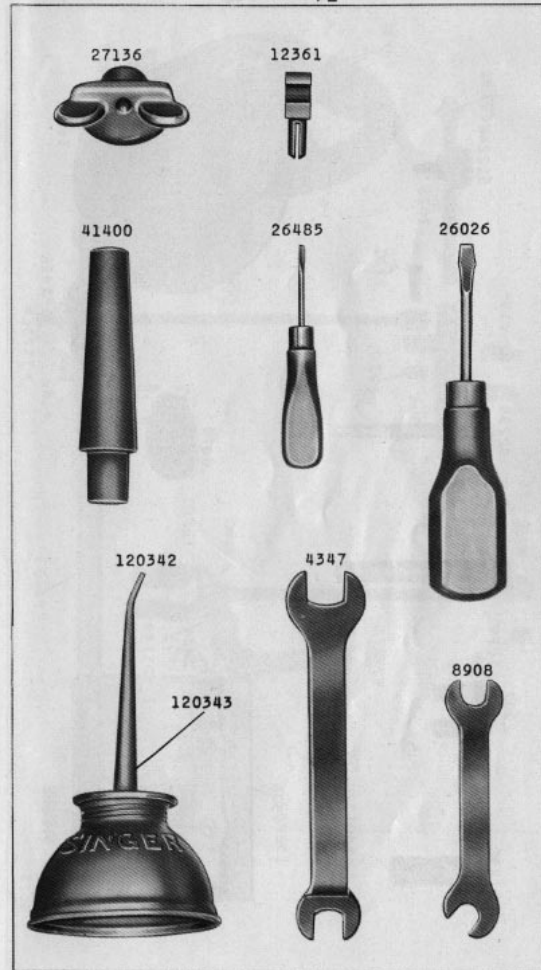

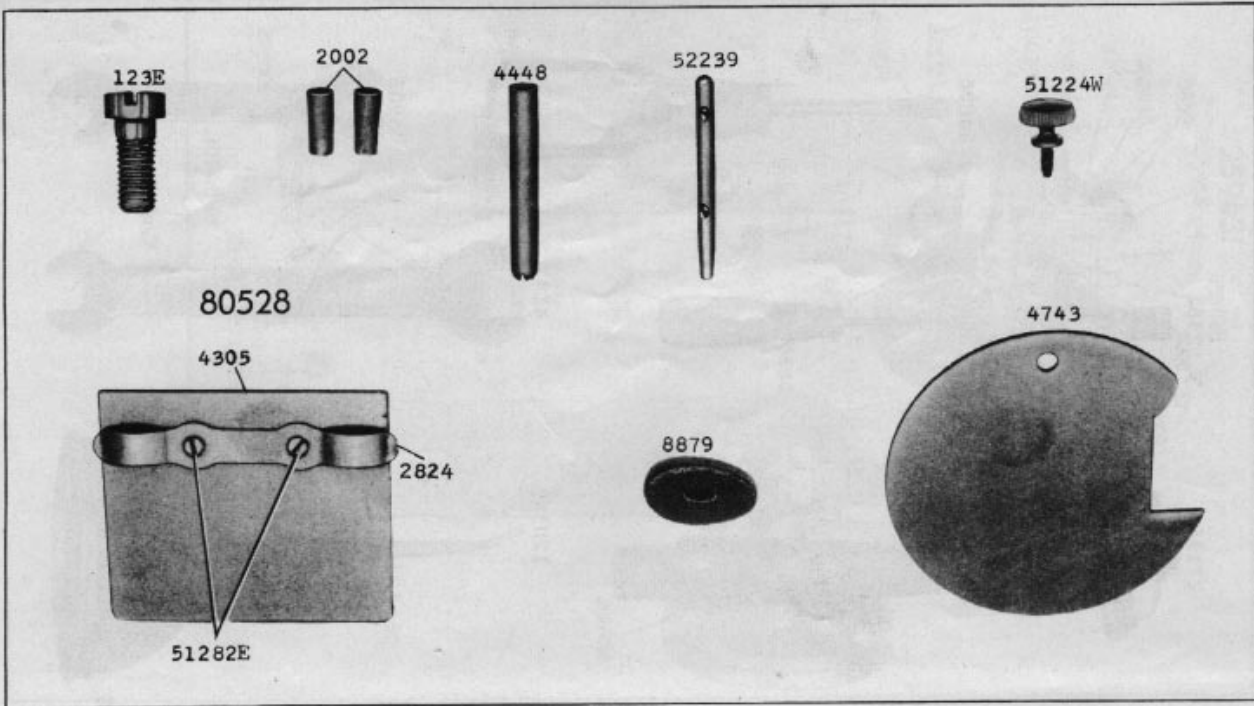

24160 2/3

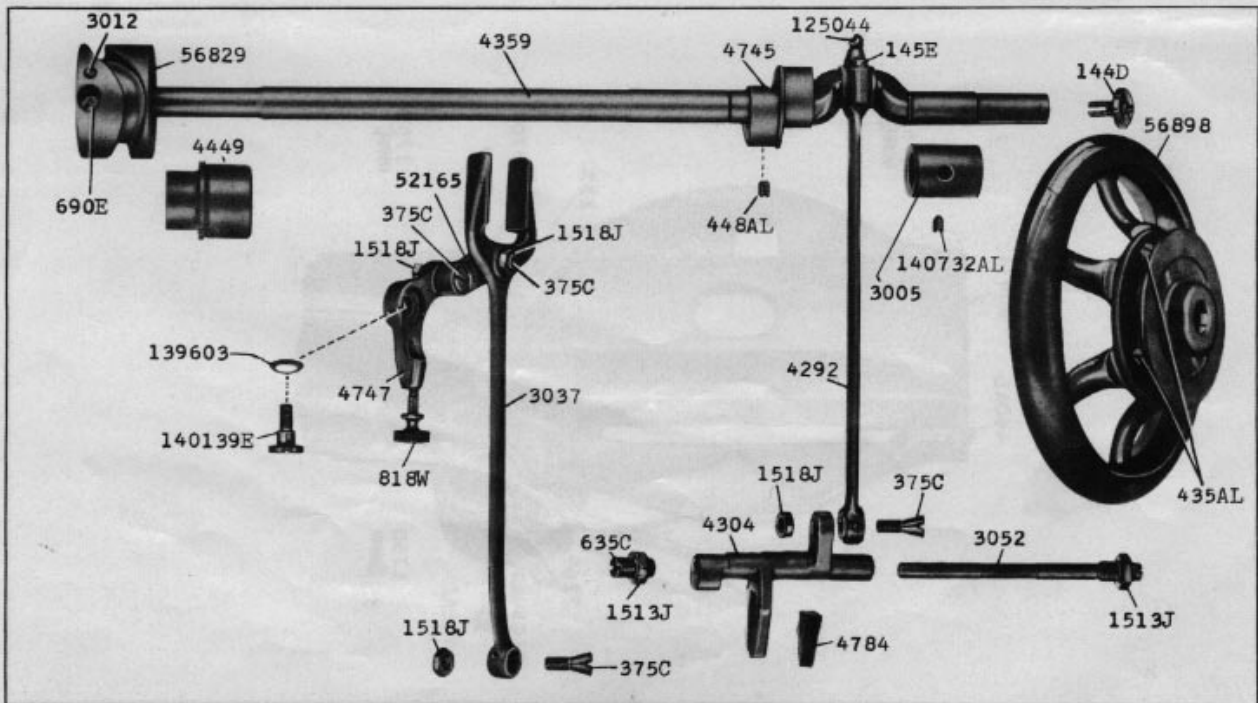

24161 1/3

24162 2/3

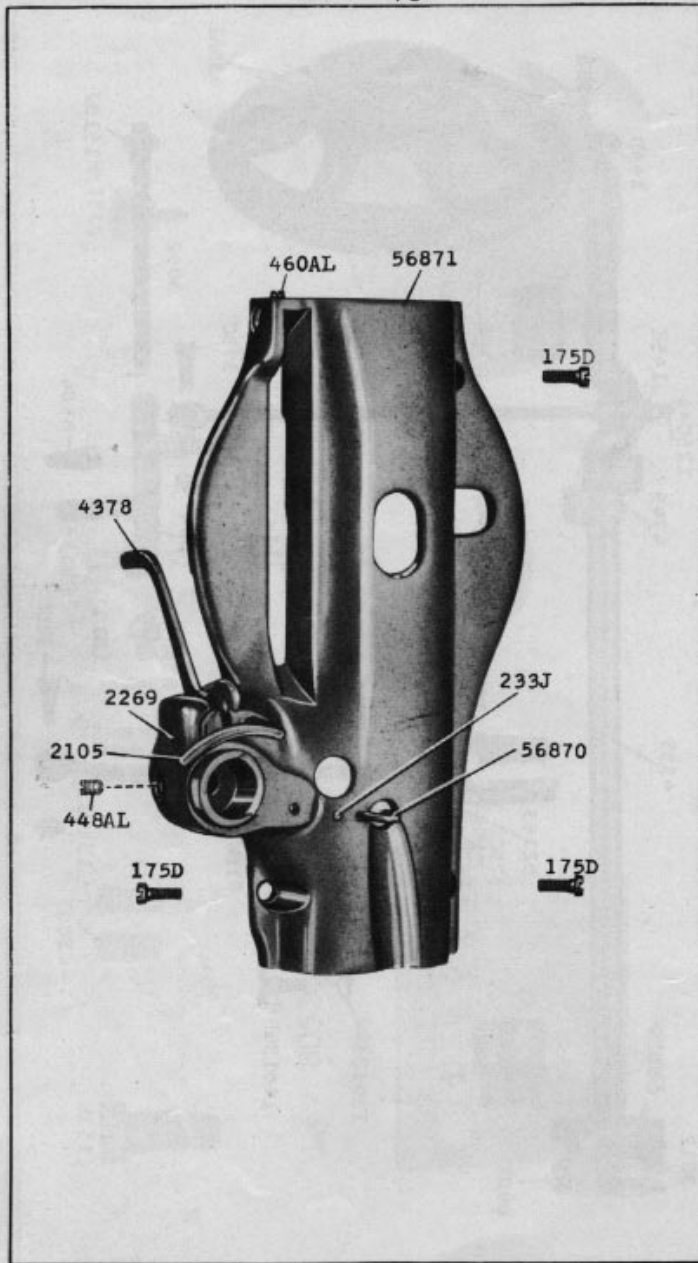

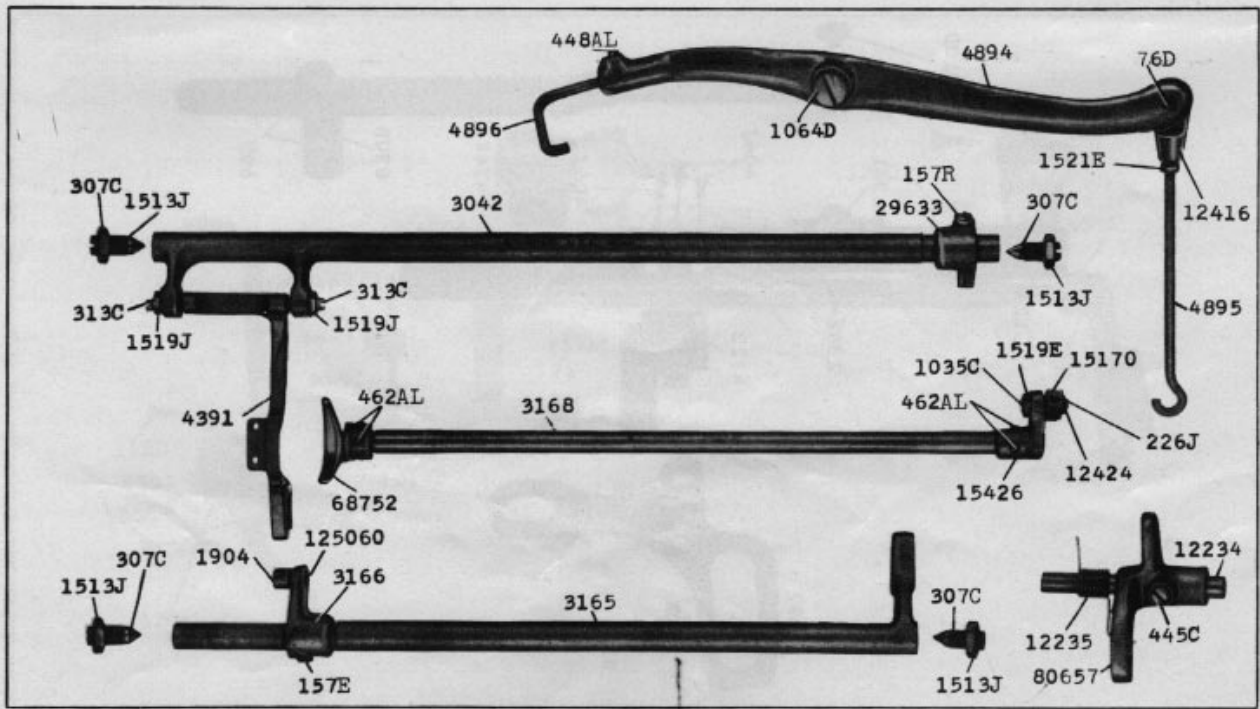

24163 1/3

24164 2/3

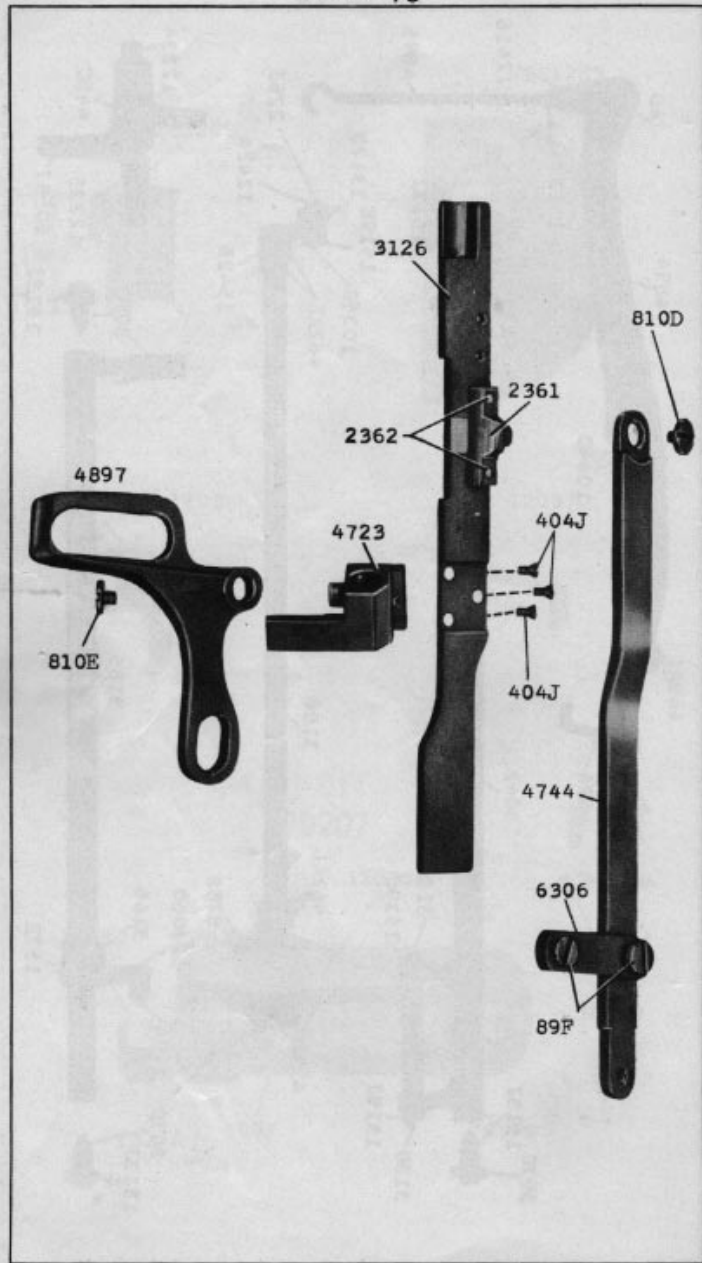

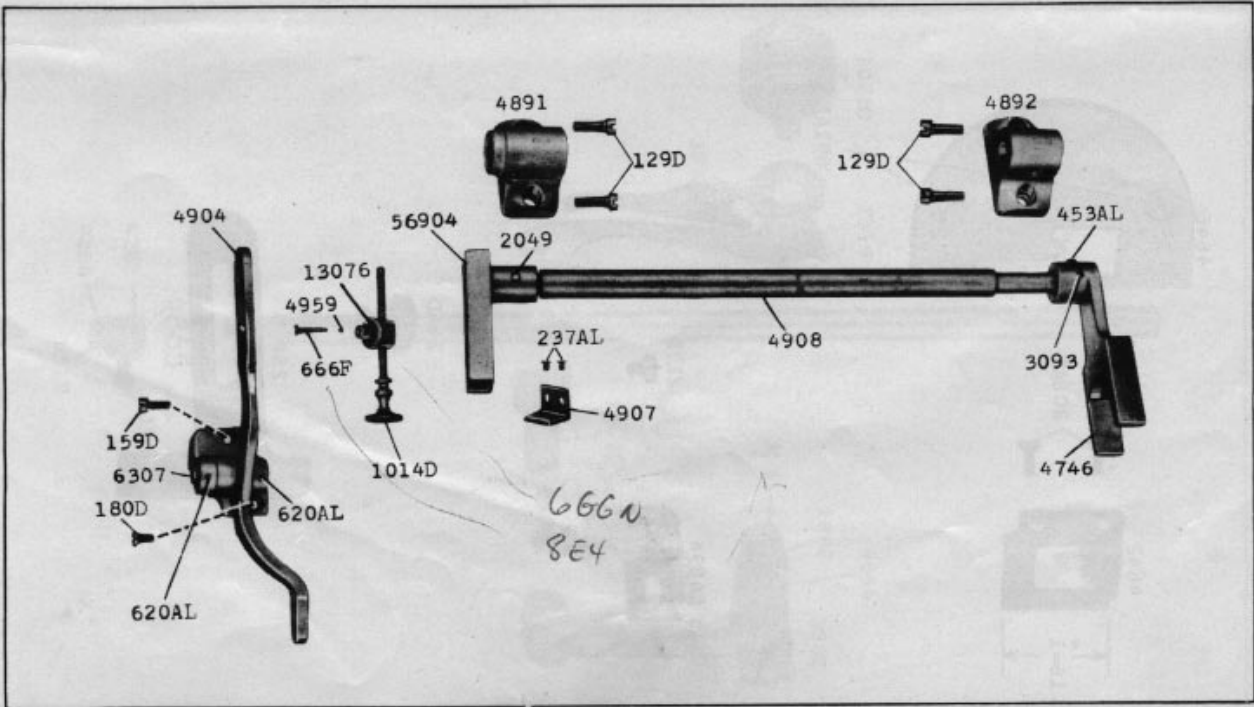

24165 1/3

24166 2/3

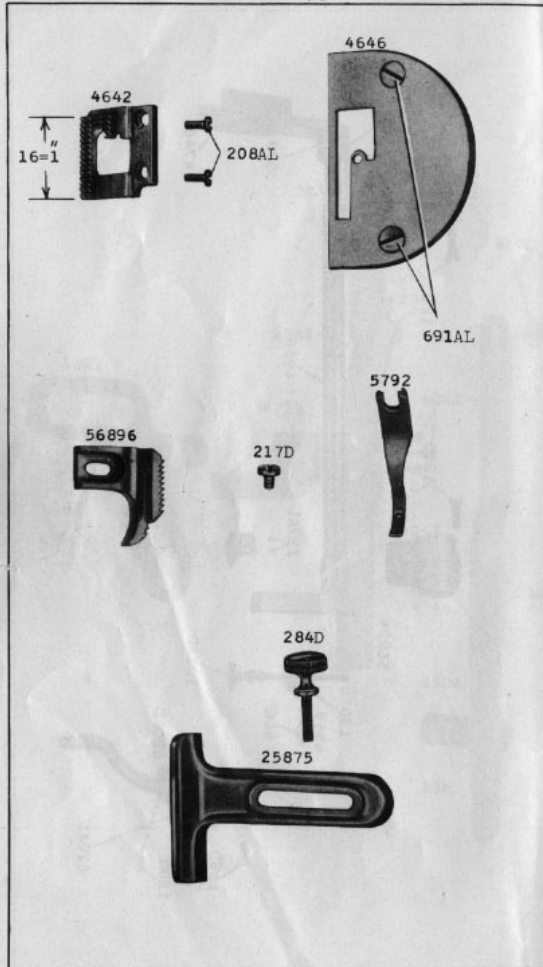

24167 2/3

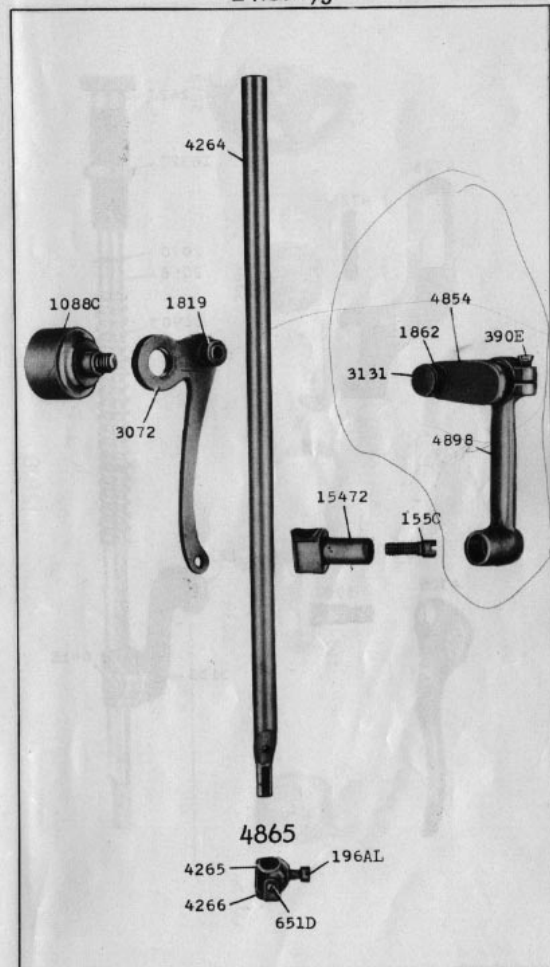

24168 2/3

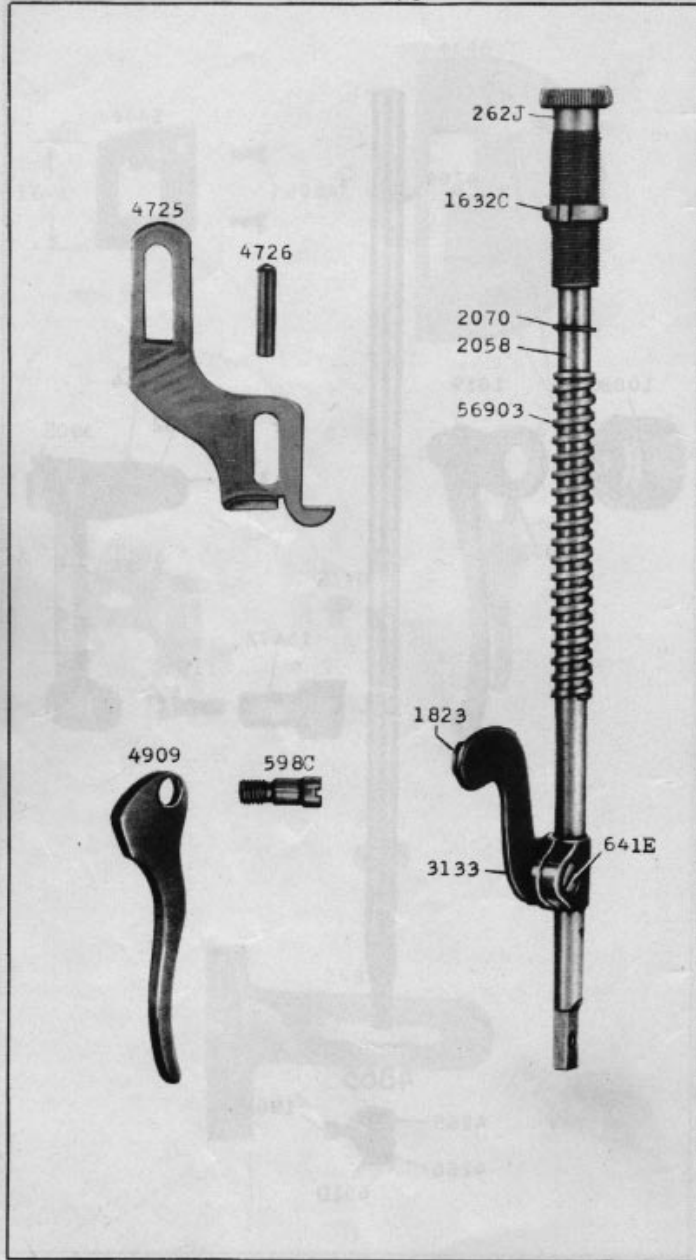

15100

125116

15277

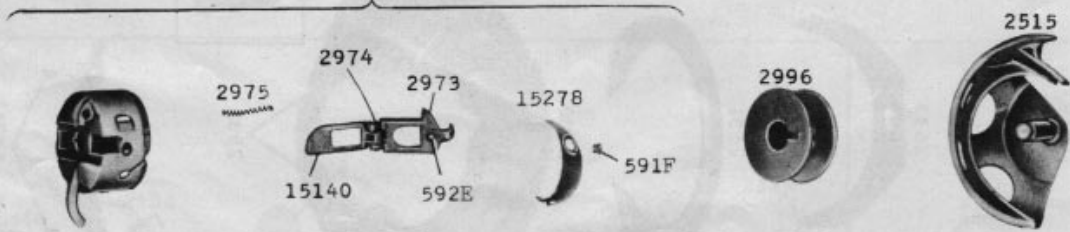

24169 2/3

24170 2/3
56897

648J

2533

2531

2530

145B

2532

145B

2535

662AL

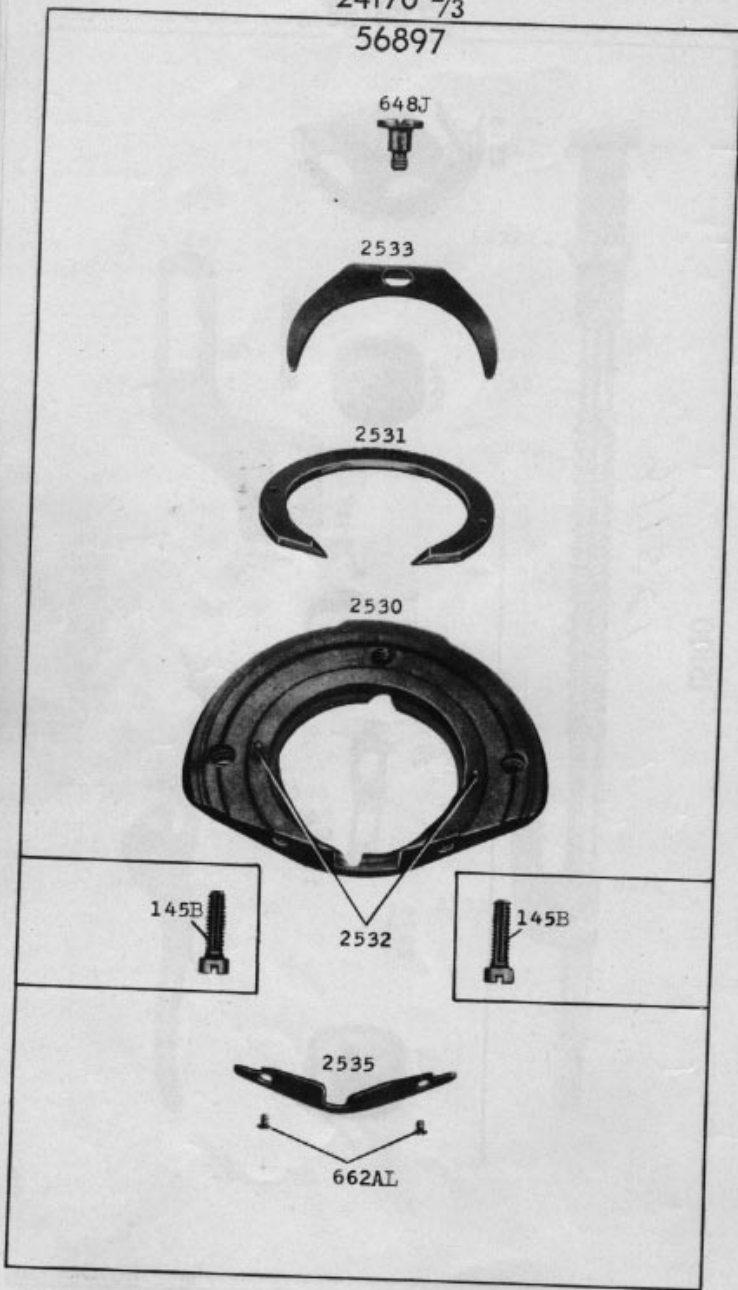

2111

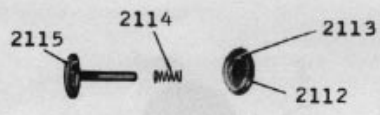

56791

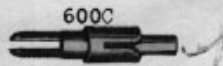

24171 2/3

24172 2/3

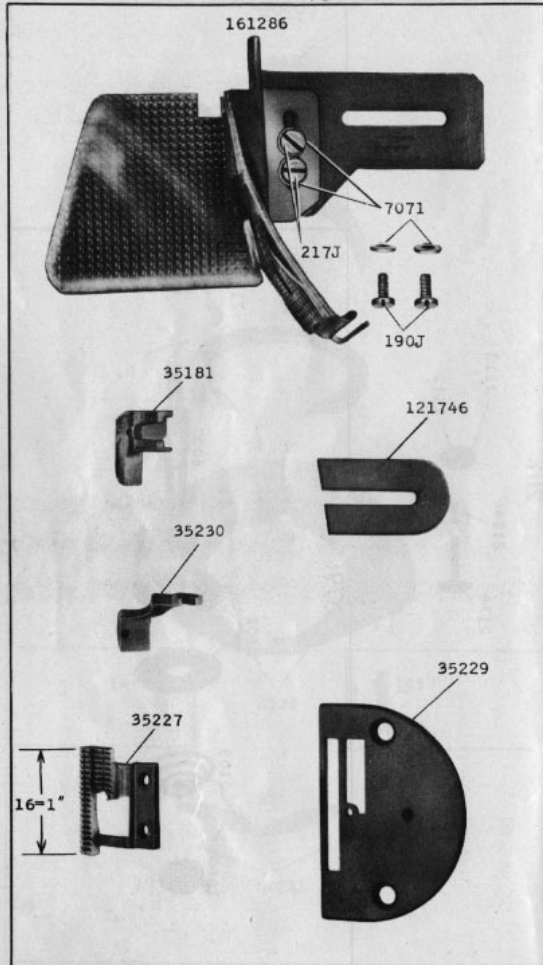

24173 2/3

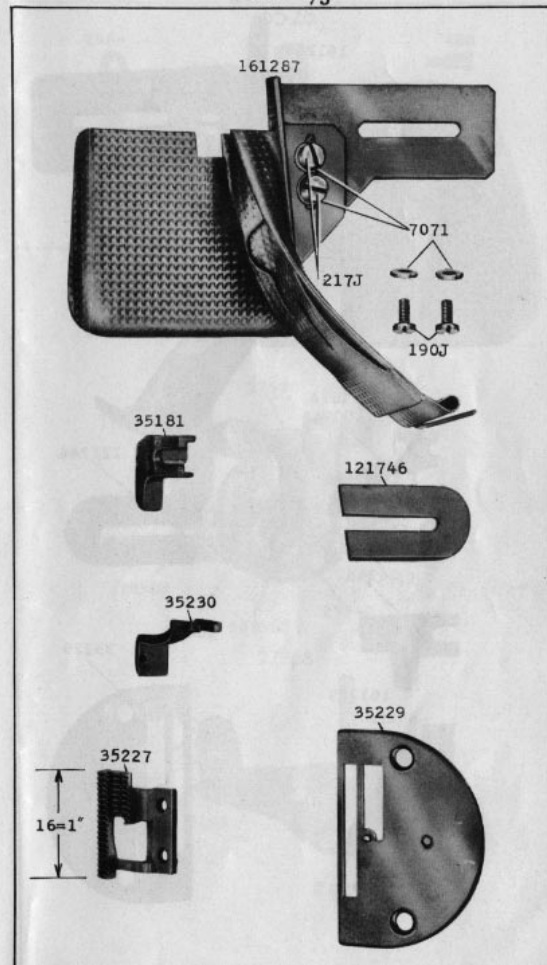

24174 2/3

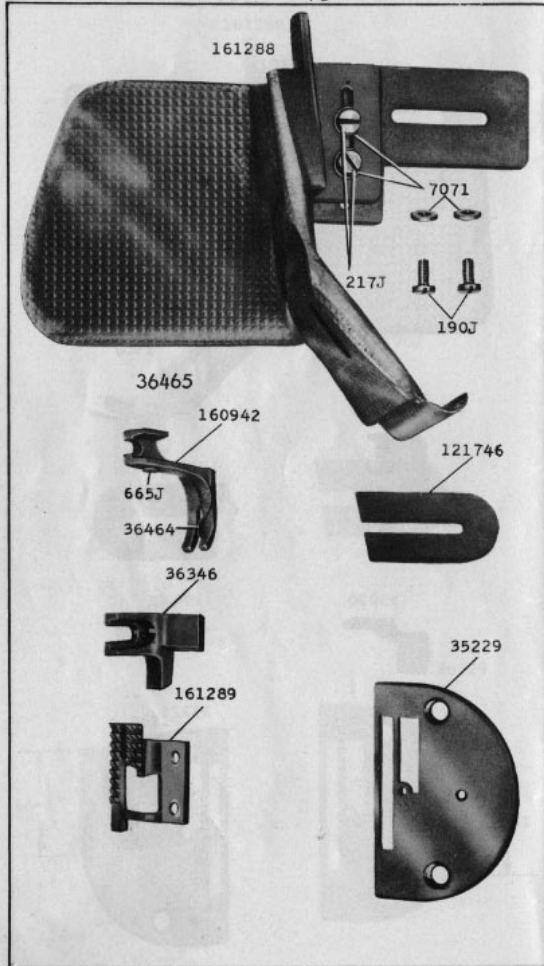

24175 1/2

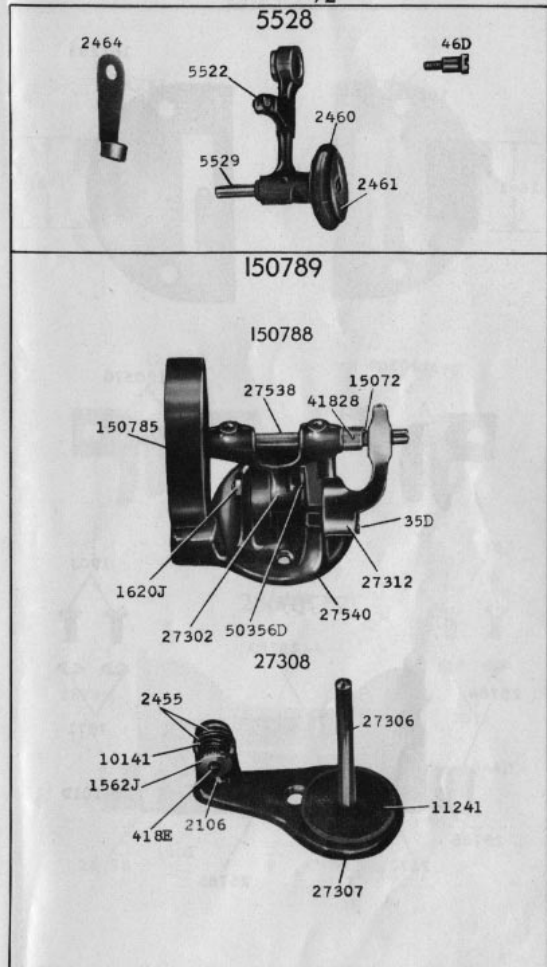

24176 $\frac{2}{3}$

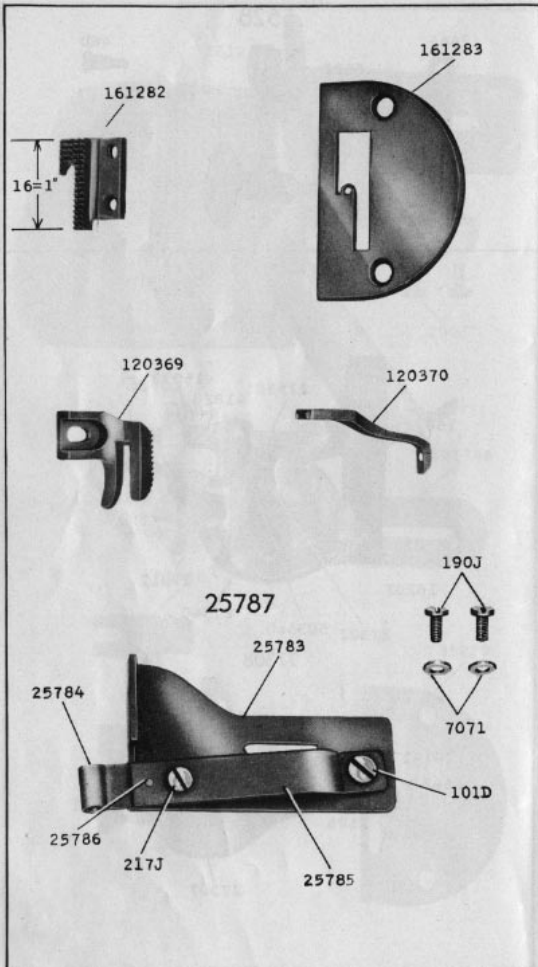

24177 $\frac{2}{3}$

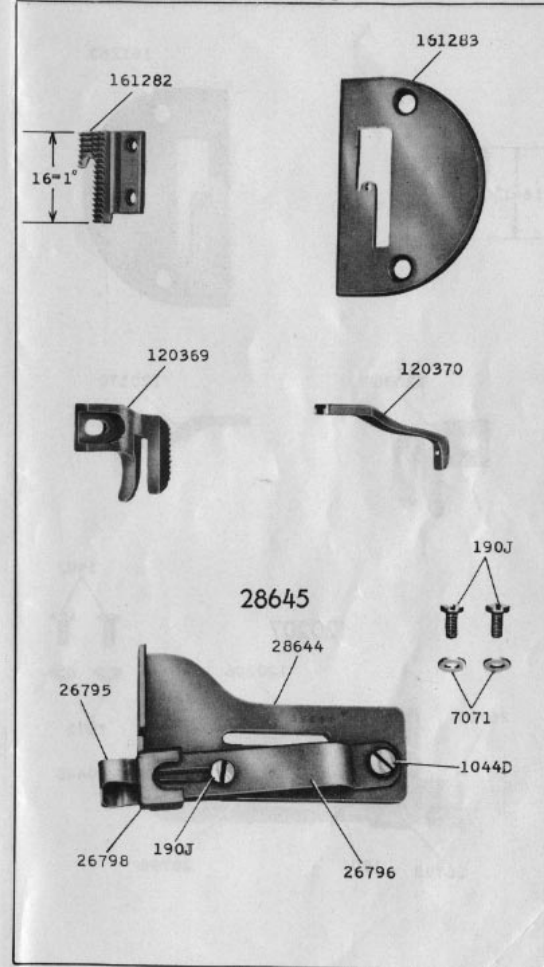

24178 2/3

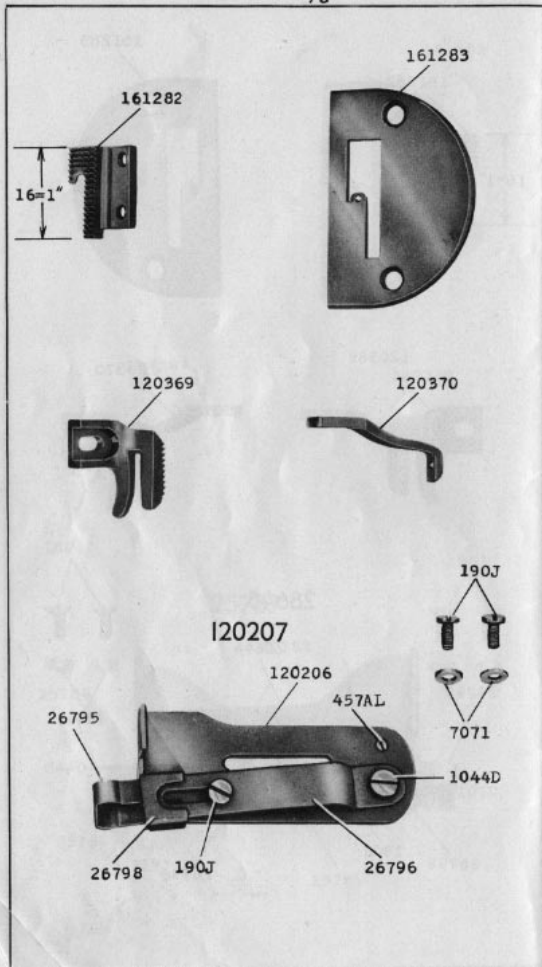

24179 2/3

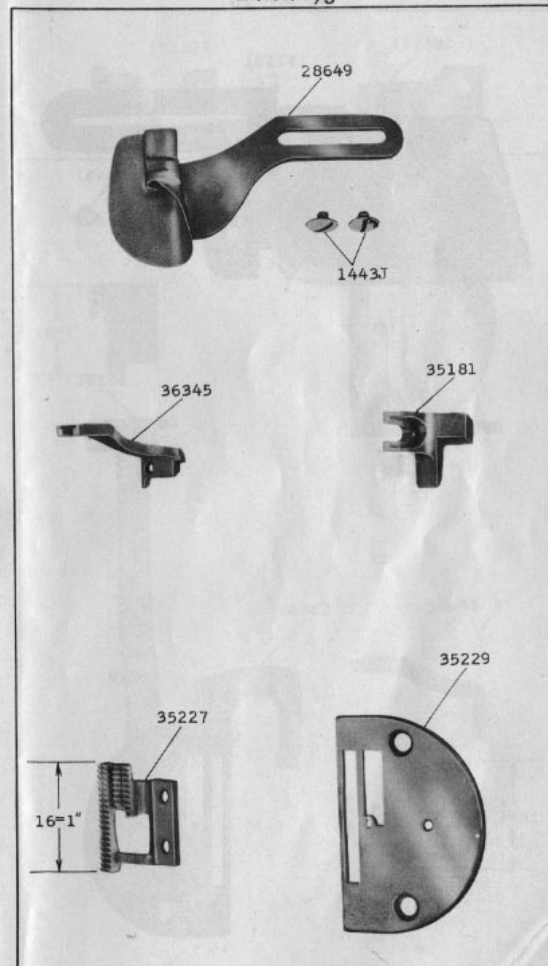

24180 $\frac{2}{3}$

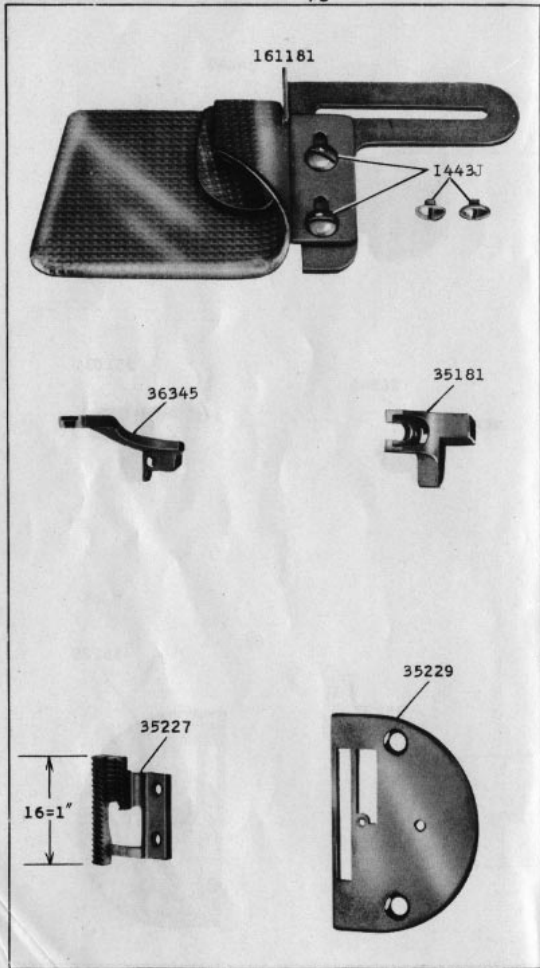

24181 $\frac{2}{3}$

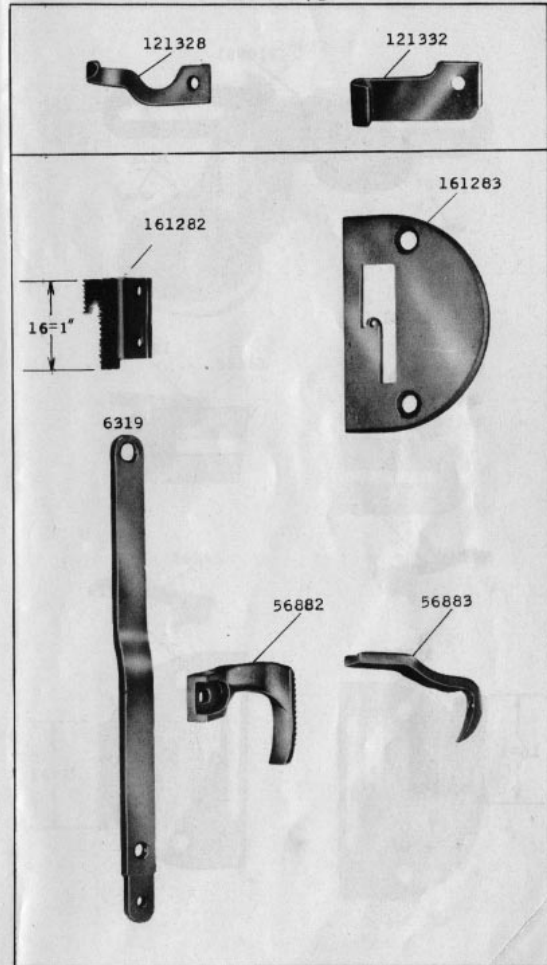

24182 $\frac{2}{3}$

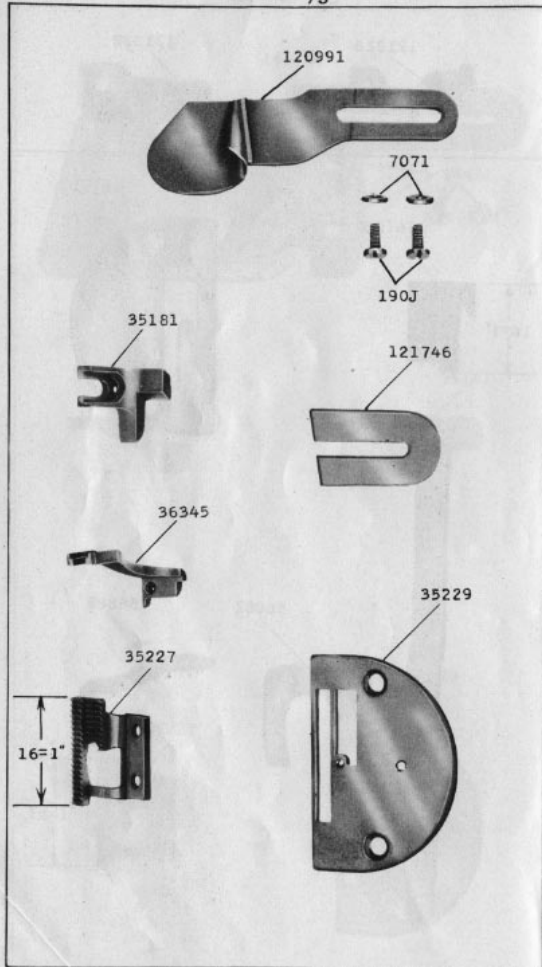

24183 $\frac{2}{3}$

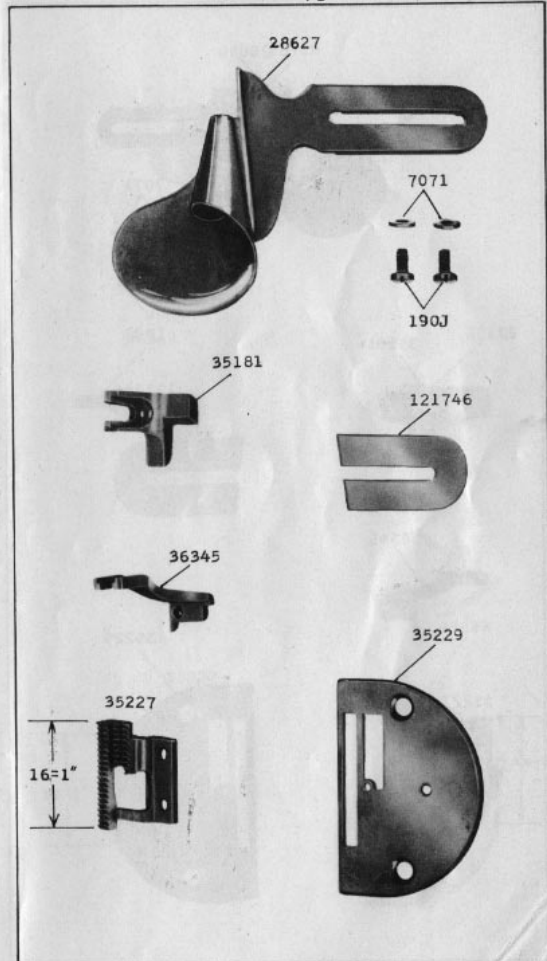

24184 2/3

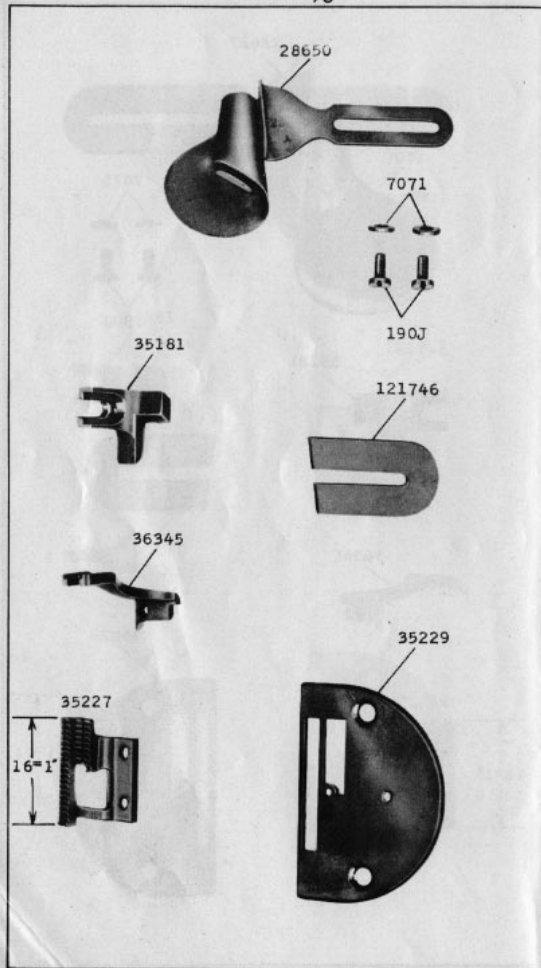

24185 2/3

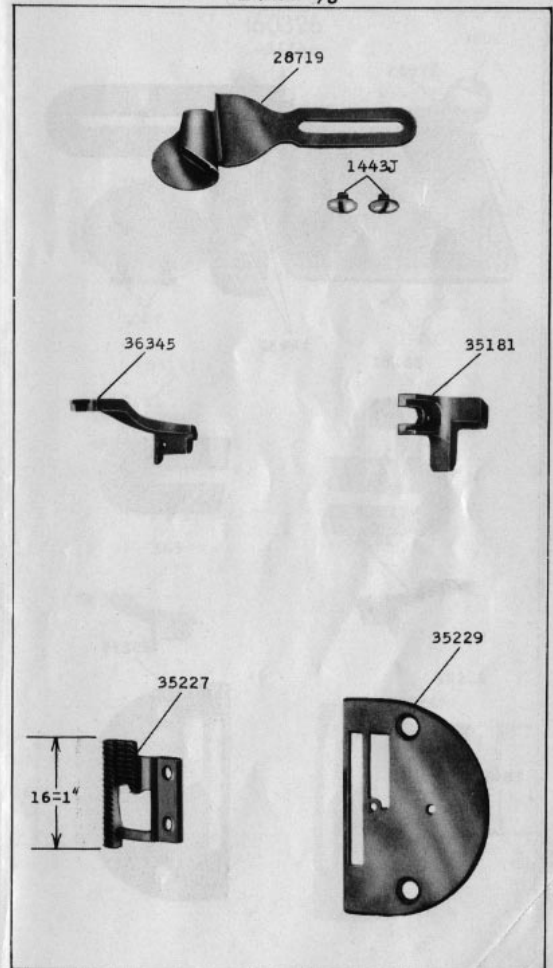

24186 2/3

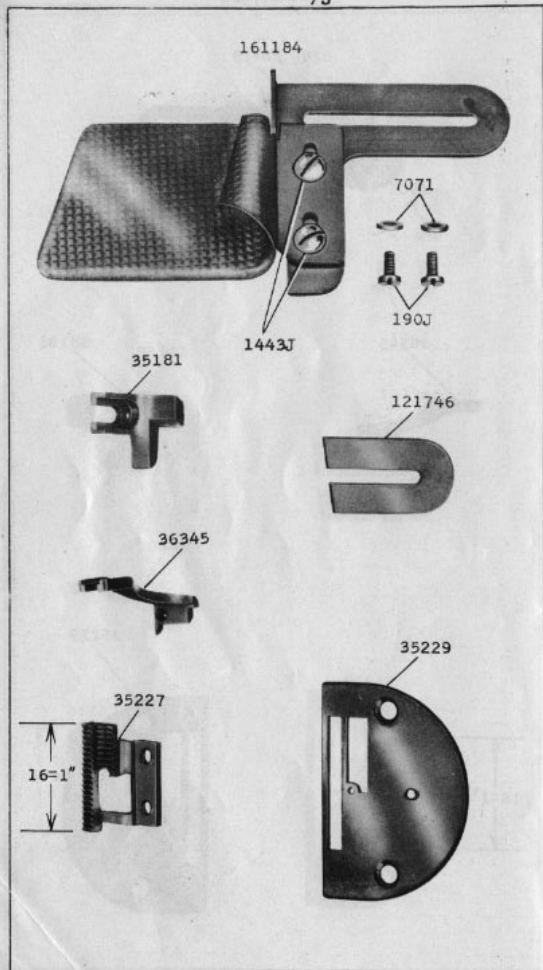

24187 2/3

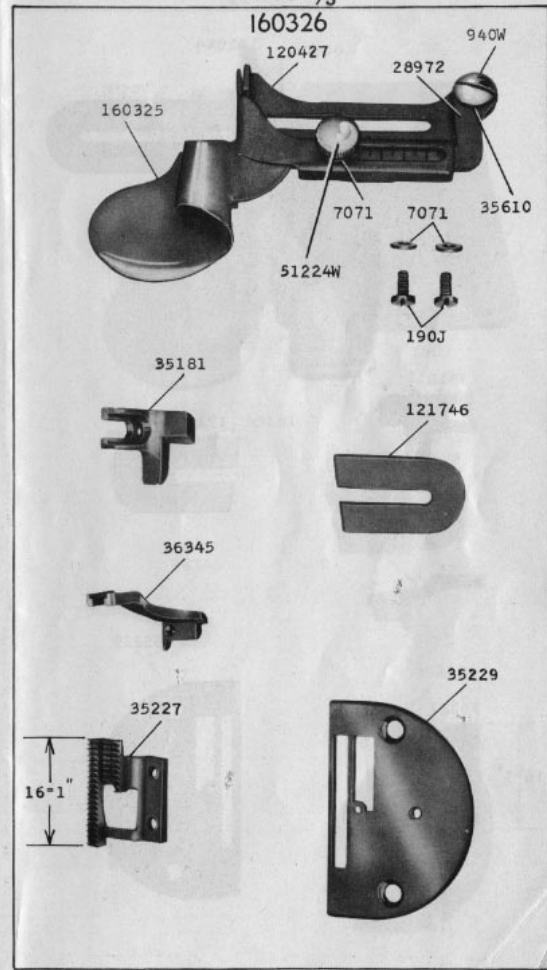

24188 2/3

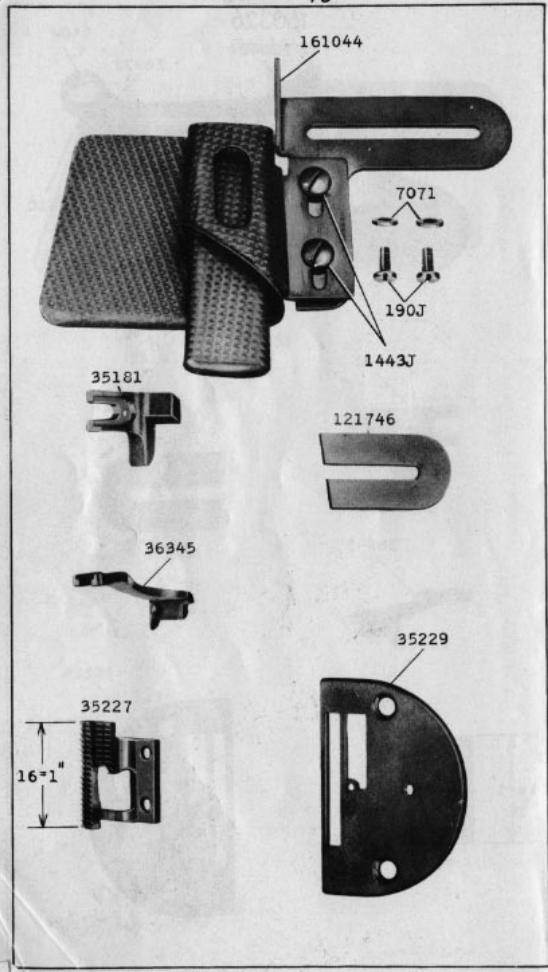

24189 2/3

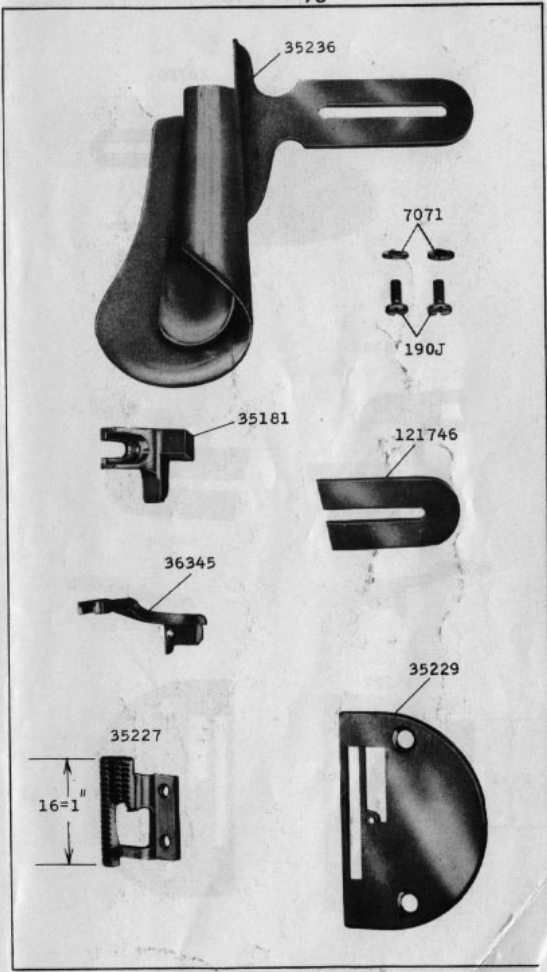

24190 2/3

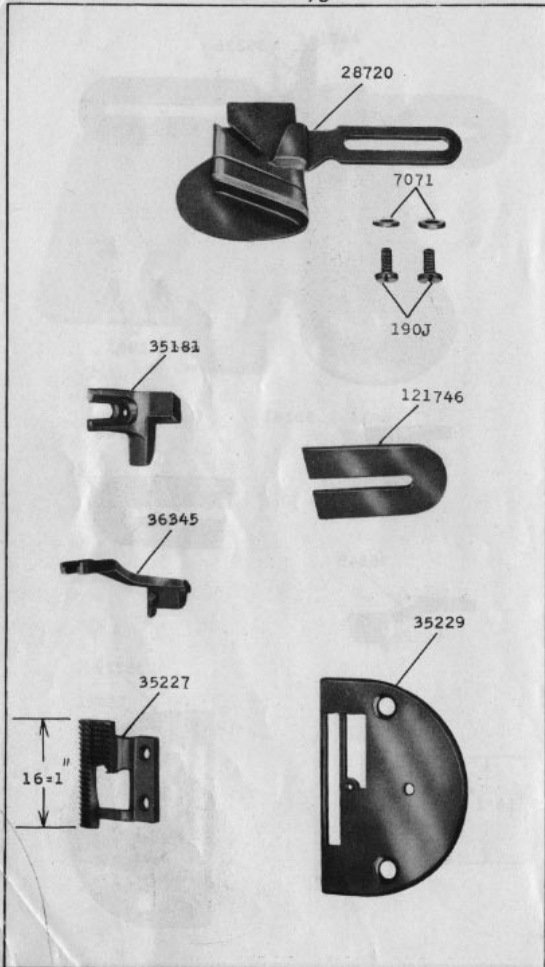

24191 2/3

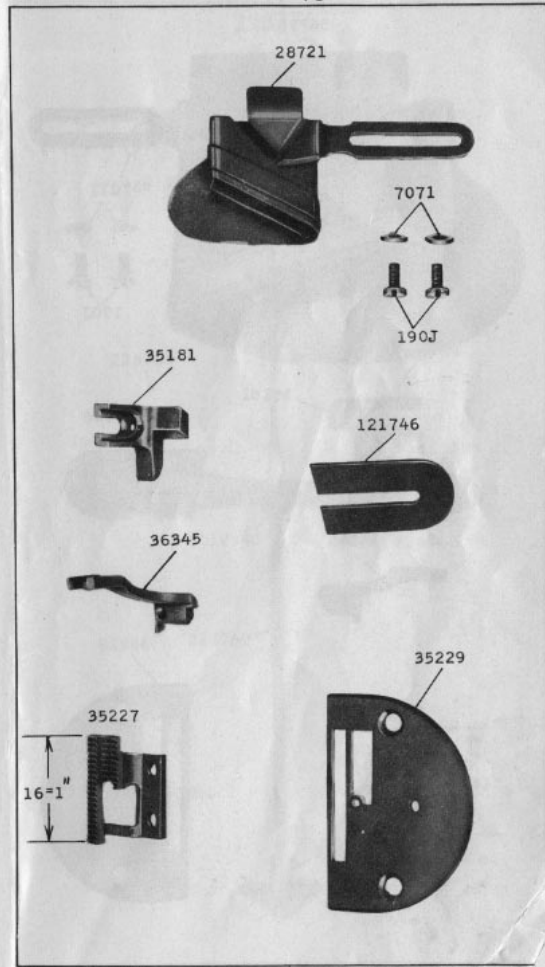

24192 $\frac{2}{3}$

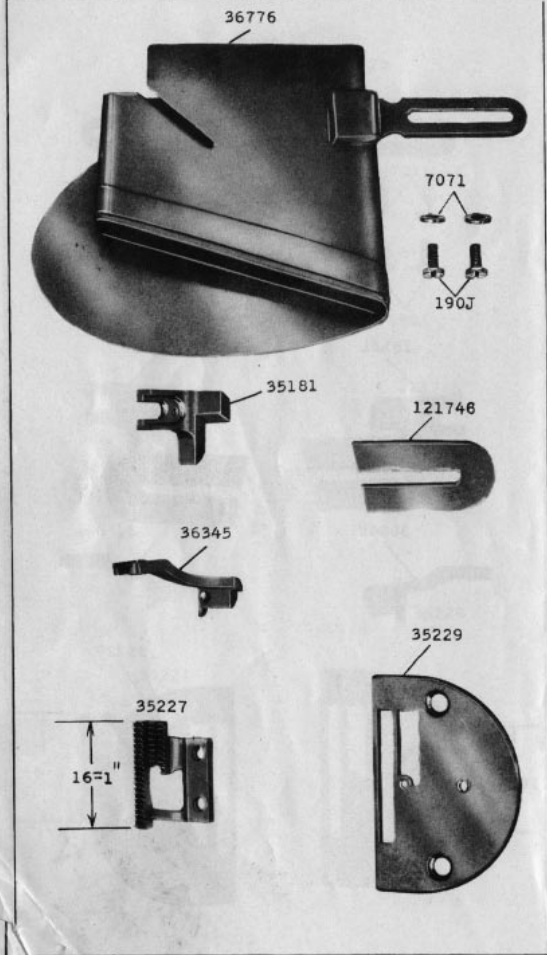

24193 $\frac{1}{6}$

228776

