

Form 19114  
(238)

**INSTRUCTIONS**  
**FOR USING**  
**SINGER SEWING MACHINES**  
**15-96 AND 15-98**

(WITH ATTACHMENTS 120603)

**LOCK STITCH, FOR FAMILY USE**

When Requiring  
Needles, Oil,  
Parts or  
Repairs for  
Your Machine



Look for the  
Red "S"  
There are  
Singer Shops in  
Every City

**THE SINGER MANUFACTURING CO.**

PRINTED IN U.S.A.



# THE IMPORTANCE OF USING SINGER OIL FOR YOUR SEWING MACHINE

---

**“The Best is the Cheapest”**

---

Knowing from many years' experience the great importance of using good oil, we put up an extra quality machine oil, in cans, especially prepared for sewing machines

**Genuine Singer Needles should be used  
in Singer Machines.  
These Needles and their Containers  
are marked with the  
Company's Trade Mark “SIMANCO.” 1**

**Needles in Containers marked  
“For Singer Machines”  
are not Singer made needles. 2**

Copyright, U. S. A., 1915, 1923, 1924, 1928, 1929, 1931,  
1932, 1933, 1935, 1937 and 1938,  
by The Singer Manufacturing Company  
All Rights Reserved for all Countries



19114

IES

USE

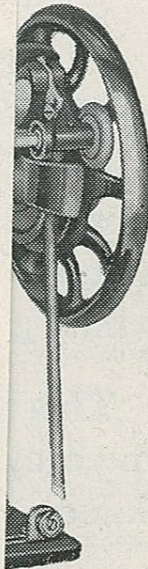

73026

THE SINGER MANUFACTURING COMPANY



As a result of new developments in recent years and the prevailing styles in women's wear, the set of attachments supplied with your sewing machine has been modernized by the substitution of the Singer Gatherer and the Singer Edge-Stitcher for the Tucker and the Cloth Guide; these two latter attachments being older and little used.

If you should have any difficulty using any of the attachments, free help and instruction will be given you gladly at the Singer Shop in your community.



19114

# SINGER SEWING MACHINES

15-96 AND 15-98

(WITH ATTACHMENTS 120603)

OSCILLATING SHUTTLE, FOR FAMILY USE

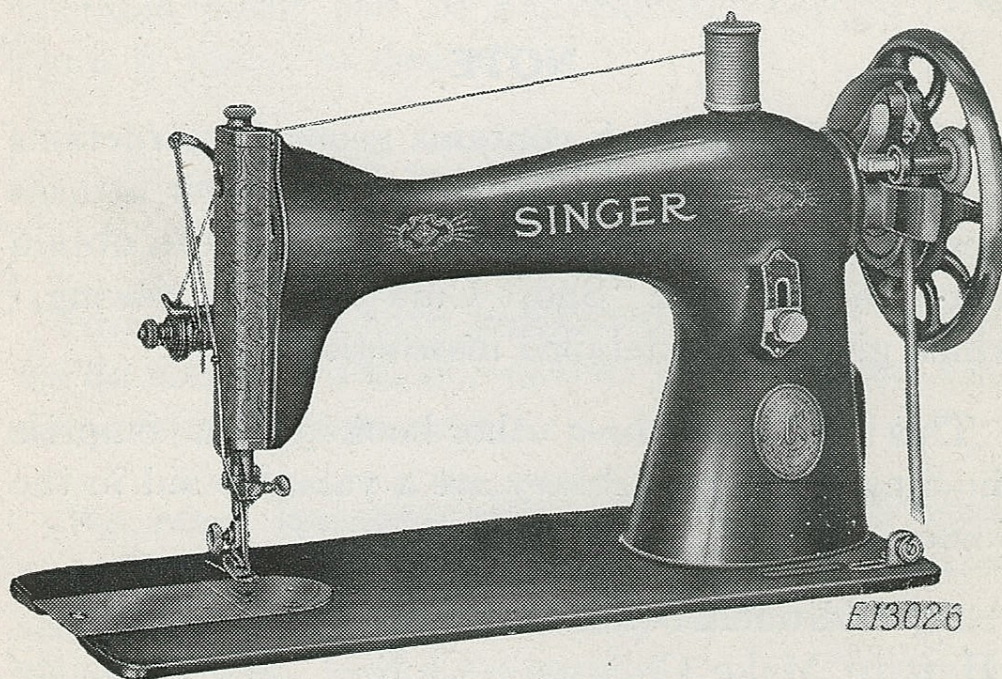

MACHINE 15-96

---

THE SINGER MANUFACTURING COMPANY



**To all whom it may concern:**

The placing or renewal of the name "Singer" (Reg. U. S. Pat. Off.) or any of the trade marks of The Singer Manufacturing Company on any machine that has been repaired, rebuilt, reconditioned, or altered in any way whatsoever outside a Singer factory or an authorized Singer agency is forbidden.

---

**NOTE**

Although this book contains general instructions covering the use of the machines and their attachments, if you are further interested, you can obtain a copy of our book "Short Cuts to Home Sewing," which gives more detailed instructions.

This book and three other books which comprise the Singer Sewing Library are a valuable aid in the home.

The additional books are: "How to Make Dresses," "How to Make Children's Clothes" and "How to Make Draperies, Slip Covers, etc."

You are also invited to take full advantage of Singer Service by calling at any of our shops for personal help with your sewing problems. You will receive courteous and prompt attention and there is no obligation.



## DESCRIPTION

**Machines 15-96** and **15-98**, for family use, each have an oscillating shuttle and make the lock stitch.

**Machine 15-96** is intended for operation by foot power and is regularly equipped with a treadle stand.

**Machine 15-98** has a hand driving attachment and is provided with a wooden base and cover. This portable outfit can be conveniently carried from place to place, as desired.

## SINGER SERVICE

Now that you have purchased your new Singer, we do not want you to feel that your relations with us have come to an end.

We hope that you will make the Singer Shop your headquarters for sewing supplies and service. Only there or through authorized, bonded Singer representatives can you secure genuine Singer oil, needles, belts, parts, etc., so important in getting the best results from your machine. And remember, only an authorized Singer representative should be allowed to touch your machine when repairs or adjustments are required.

World-wide Singer Service has no equal. Use it!



## To Operate the Treadle Machine

Raise the presser foot (B) by means of the presser bar lifter (C) to prevent injury to the foot (B) and feed (A).

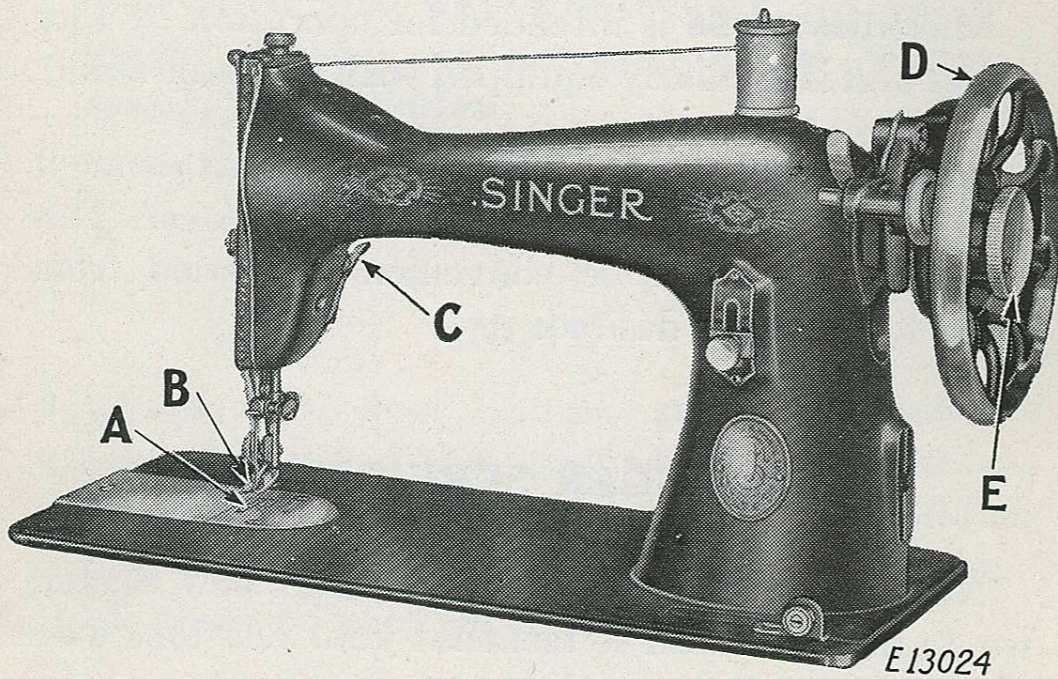

FIG. 2. FRONT VIEW OF MACHINE 15-96

It is necessary to understand the stop motion (E) by which the balance wheel (D) can be released when required, thus enabling the operator to become proficient in the use of the treadle, and permitting the winding of bobbins without running the stitching mechanism. It also allows the operator to wind bobbins without removing partially sewn work and without unthreading the machine.



To release the balance wheel (D, Fig. 2) turn the stop motion screw (E, Fig. 2) over toward you. It will be necessary to hold the balance wheel while loosening the stop motion screw.

After releasing the balance wheel, place your feet upon the treadle and with the right hand turn the balance wheel over toward you. This will start the band wheel, treadle and pitman, the sewing mechanism having been disconnected.

Continue the motion thus begun by an alternate pressure of heel and toe, until a regular and easy movement is acquired, and the balance wheel kept in continuous rotation by use of the feet alone.

When you are thoroughly familiar with the treadle movement and can restart the machine without turning the balance wheel in the wrong direction, tighten the stop motion screw to connect the balance wheel with the stitching mechanism.

Place a piece of cloth under the presser foot, let the foot down upon it, and operate the machine in this way without being threaded, until you have become accustomed to guiding the material.



### To Operate the Hand Machine

After removing the wooden cover from the machine, turn the lever (H) back until it enters the socket (G) as shown, then turn the hinged finger (F) back between the spokes of the balance wheel.

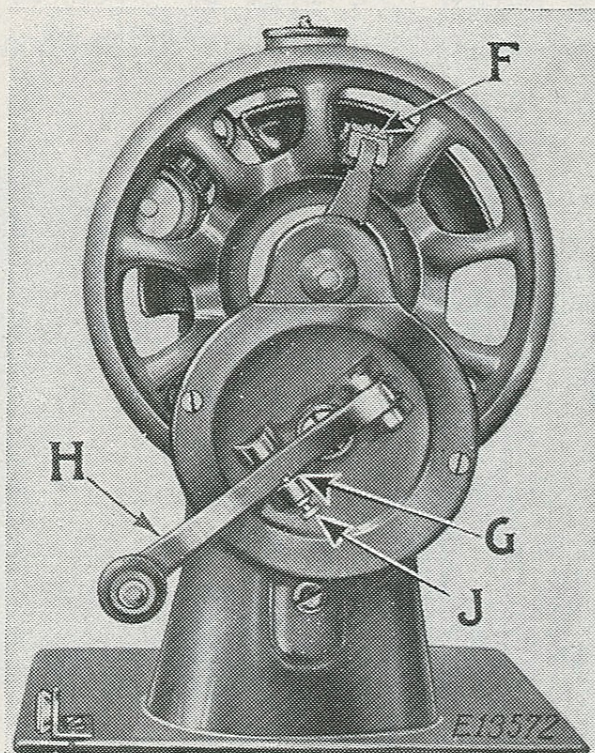

FIG. 3. END VIEW OF MACHINE 15-98, SHOWING THE HAND DRIVING ATTACHMENT

Raise the presser foot (B, Fig. 2) by means of the presser bar lifter (C, Fig. 2) to prevent injury to the foot (B, Fig. 2) and feed (A, Fig. 2).

It is necessary to understand the stop motion (E, Fig. 2) by which the balance wheel (D, Fig. 2) can be released when required, thus enabling the operator to become proficient in the use of the hand driving attachment and permitting the winding of bobbins without running the stitching mechanism. It also allows the operator to wind bobbins without removing partially sewn work and without unthreading the machine.



To release the balance wheel (D, Fig. 2), turn the stop motion screw (E, Fig. 2) over toward you. It will be necessary to hold the balance wheel while loosening the stop motion screw.

After releasing the balance wheel, turn the lever (H, Fig. 3) of the hand driving attachment over from you, continuing the motion thus begun until a regular and easy movement is acquired.

When you are thoroughly familiar with the movement of the hand driving attachment, tighten the stop motion screw to connect the balance wheel with the stitching mechanism.

Place a piece of cloth under the presser foot; let the foot down upon it, and operate the machine in this way, without being threaded, until you have become accustomed to guiding the material with the left hand.

NOTE. To release the lever (H) from the socket (G), it is necessary to first withdraw the plunger (J).

### **To Insure Perfect Action of the Machine**

The balance wheel must always turn over toward the operator.

Do not run the machine with the presser foot resting on the feed without cloth under the presser foot.

Do not run the machine when both bobbin case and needle are threaded, unless there is material under the presser foot.

Do not try to help the machine by pulling the fabric, lest you bend the needle. The machine feeds the work without assistance.

The slide over the bobbin case should be kept closed when the machine is in operation.



### To Remove the Bobbin

Turn the balance wheel over toward you until the thread take-up lever (5, Fig. 12) is raised to

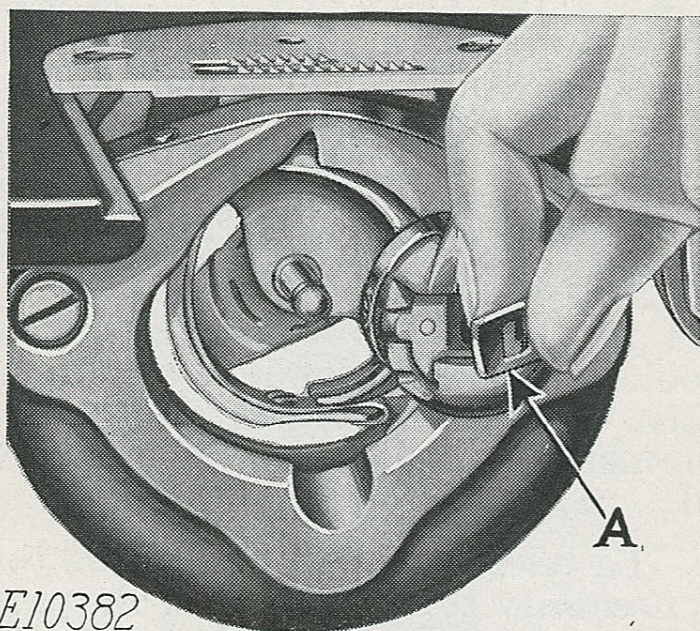

FIG. 4. REMOVING THE BOBBIN CASE

its highest position. Draw to the left the slide in the bed of the machine. Reach down with the thumb and forefinger of the left hand, open the bobbin case latch (A, Fig. 4) and lift out the bobbin case. While the latch remains open, the bobbin is retained in the bobbin case. Release the latch, turn the open end of the bobbin case downward and the bobbin will drop out.

### To Wind the Bobbin

Release the balance wheel (D, Fig. 2) by turning the stop motion screw (E, Fig. 2) over toward you. It is necessary to hold the balance wheel (D) while loosening the stop motion screw.



Place the bobbin on the bobbin winder spindle and push it up closely against the shoulder, having

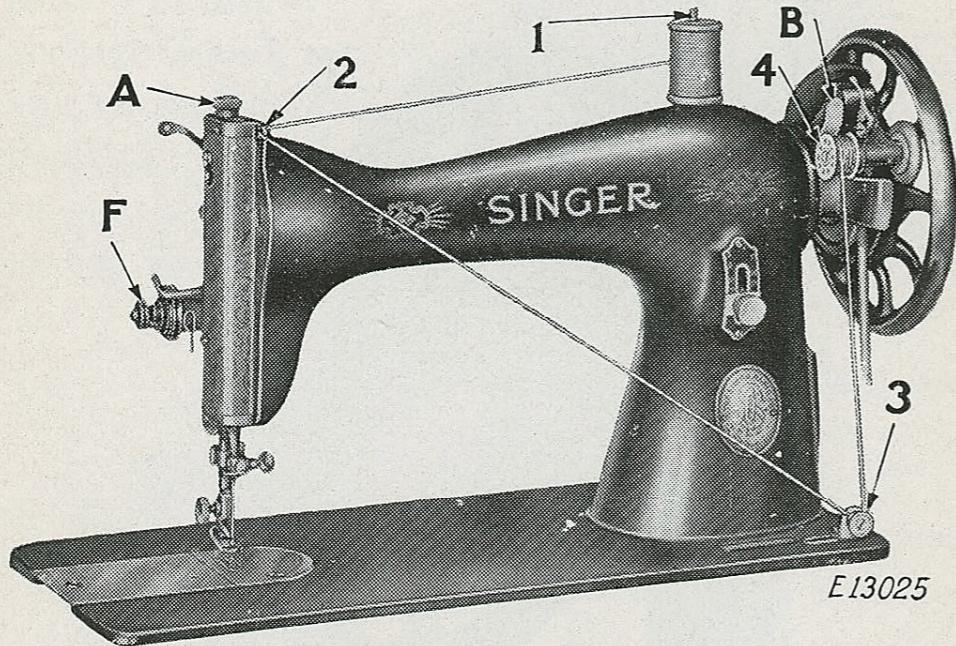

FIG. 5. WINDING THE BOBBIN

the small pin in the shoulder enter the hole in the side of the bobbin. Put the spool of thread on the spool pin (1, Fig. 5). Pass the thread into the thread guide (2, Fig. 5) at the top of the face plate, then from left to right under and between the tension discs (3) on the bed of the machine, then pass the thread up and through one of the holes (4) in the left side of the bobbin, from the inside. Press down on the bobbin and the bobbin winder latch (B, Fig. 5) will drop down and hold the bobbin winder pulley against the hub of the balance wheel. Then operate the machine the same as for sewing.

The end of the thread must be held by hand until a few coils are wound and should then be broken off. When sufficient thread has been wound upon the bobbin, the bobbin winder is automatically released from the balance wheel.



If the pressure of the bobbin winder pulley against the hub of the balance wheel is insufficient for winding the bobbin, press down the bobbin winder until

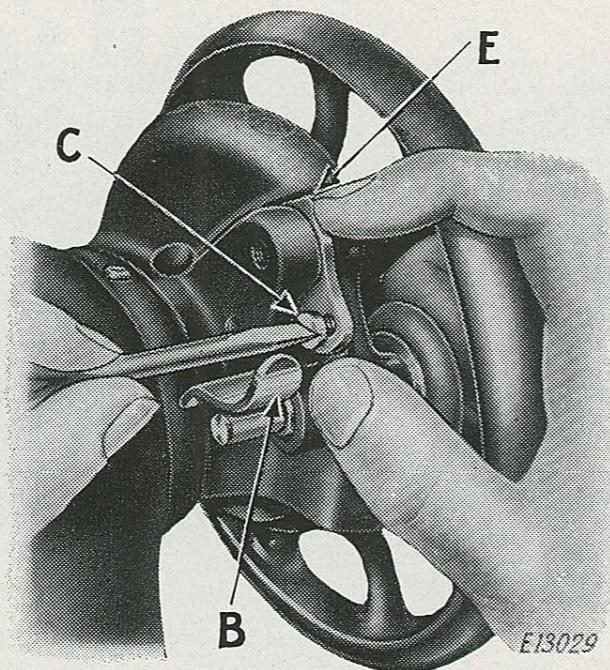

FIG. 6. ADJUSTMENT OF BOBBIN WINDER

the latch (B, Fig. 6) drops down and holds it, then loosen the adjusting screw (C, Fig. 6). With the forefinger, push back the upper end of the slotted plate (E) as far as it will go, as shown in Fig. 6, and at the same time press the bobbin winder pulley against the hub of the balance wheel, then tighten the adjusting screw (C).

If the thread does not wind evenly on the bobbin, loosen the screw which holds the tension bracket (3, Fig. 5) in position on the bed of the machine and move the tension bracket to the right or left, as may be required, then tighten the screw.



## To Thread the Bobbin Case

Hold the bobbin between the thumb and forefinger of the right hand, with the thread on top drawing from left to right, as shown in Fig. 7.

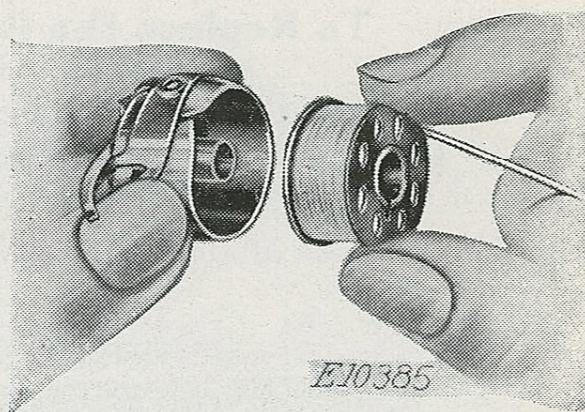

FIG. 7

With the left hand hold the bobbin case as shown in Fig. 7, the slot in the edge being at the top, and place the bobbin into the bobbin case.

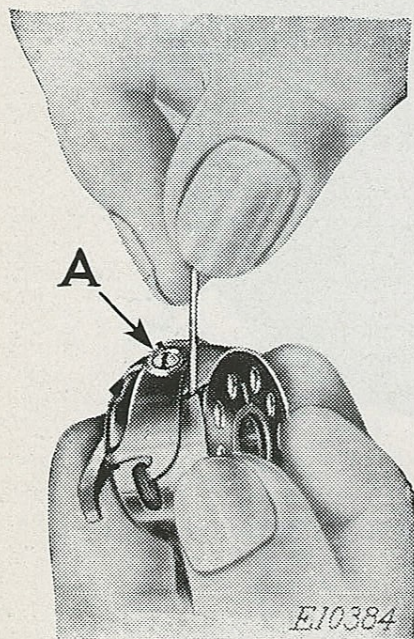

FIG. 8

Then pull the thread into the slot as shown in Fig. 8, and back under the tension spring into the slot at the end of the tension spring, as shown in Fig. 9.

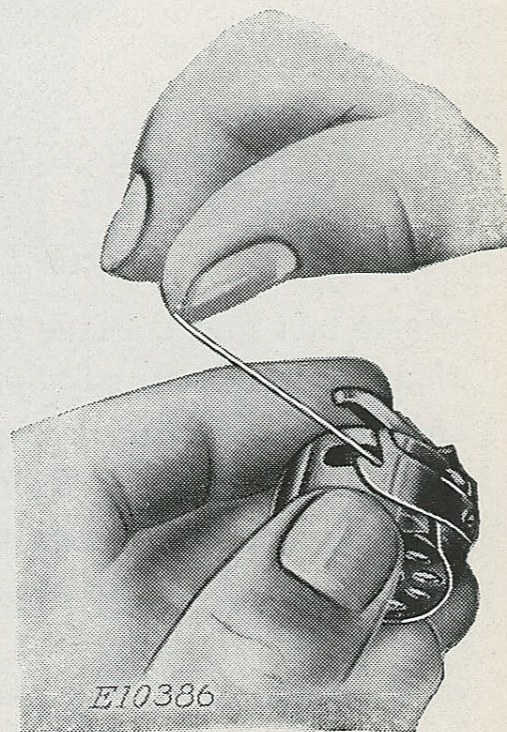

FIG. 9



### To Replace the Bobbin Case

After threading, take the bobbin case by the latch, holding it between the thumb and forefinger

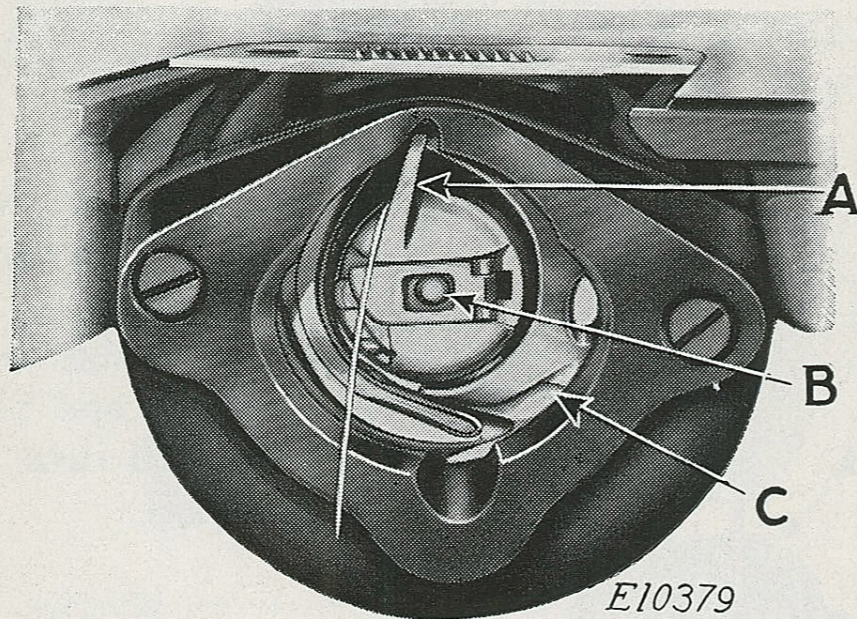

FIG. 10. BOBBIN CASE THREADED AND REPLACED

of the left hand. Place the bobbin case on the center stud (B, Fig. 10) of the shuttle body with the position finger (A, Fig. 10) opposite the notch at the top of the shuttle race. Release the latch and press the bobbin case back until the latch catches the groove near the end of the stud. Allow about three inches of thread to hang free from the bobbin case and close the slide in the bed of the machine.



### To Set the Needle

Turn the balance wheel over toward you until the needle bar is at its highest position, and loosen the thumb screw (A, Fig. 11) in the needle clamp.

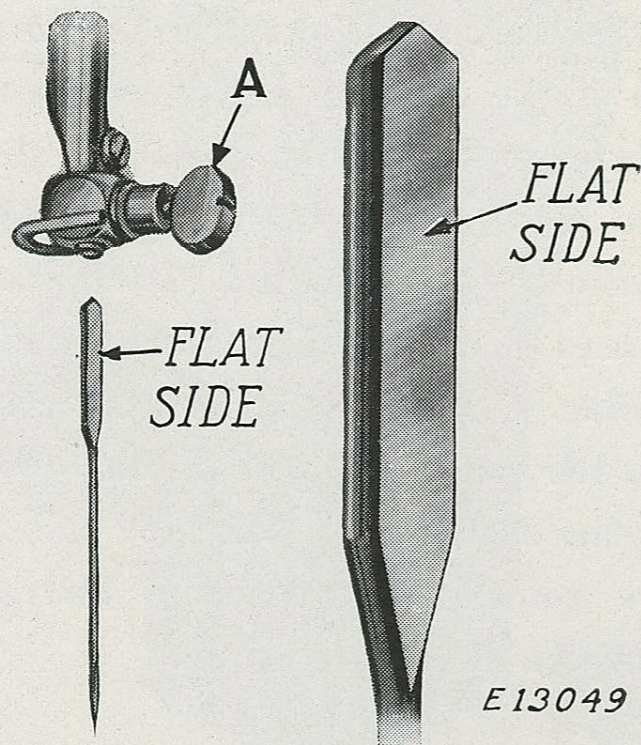

FIG. 11. POSITIONING OF NEEDLE  
IN NEEDLE CLAMP

Have the flat side of the shank of the needle toward the right as shown above and put the needle up into the clamp as far as it will go. Then tighten the thumb screw.



## Upper Threading

(SEE FIG. 12)

Turn the balance wheel over toward you until the thread take-up lever (5) is raised to its highest position. Place the spool of thread on the spool pin at the top of the machine and pass the thread to the left through the thread guide (1) at the rear of the face plate, down, under and from back to front between the tension discs (2), up back of the tension thread guard (3), down into the loop of the take-up spring (4), up and from back to front through the hole in the end of the thread take-up lever (5), down into the eyelet (6) on the face plate, into the lower wire guide (7), then from **left to right** through the eye of the needle (8).

Draw about two inches of thread through the eye of the needle with which to commence sewing.



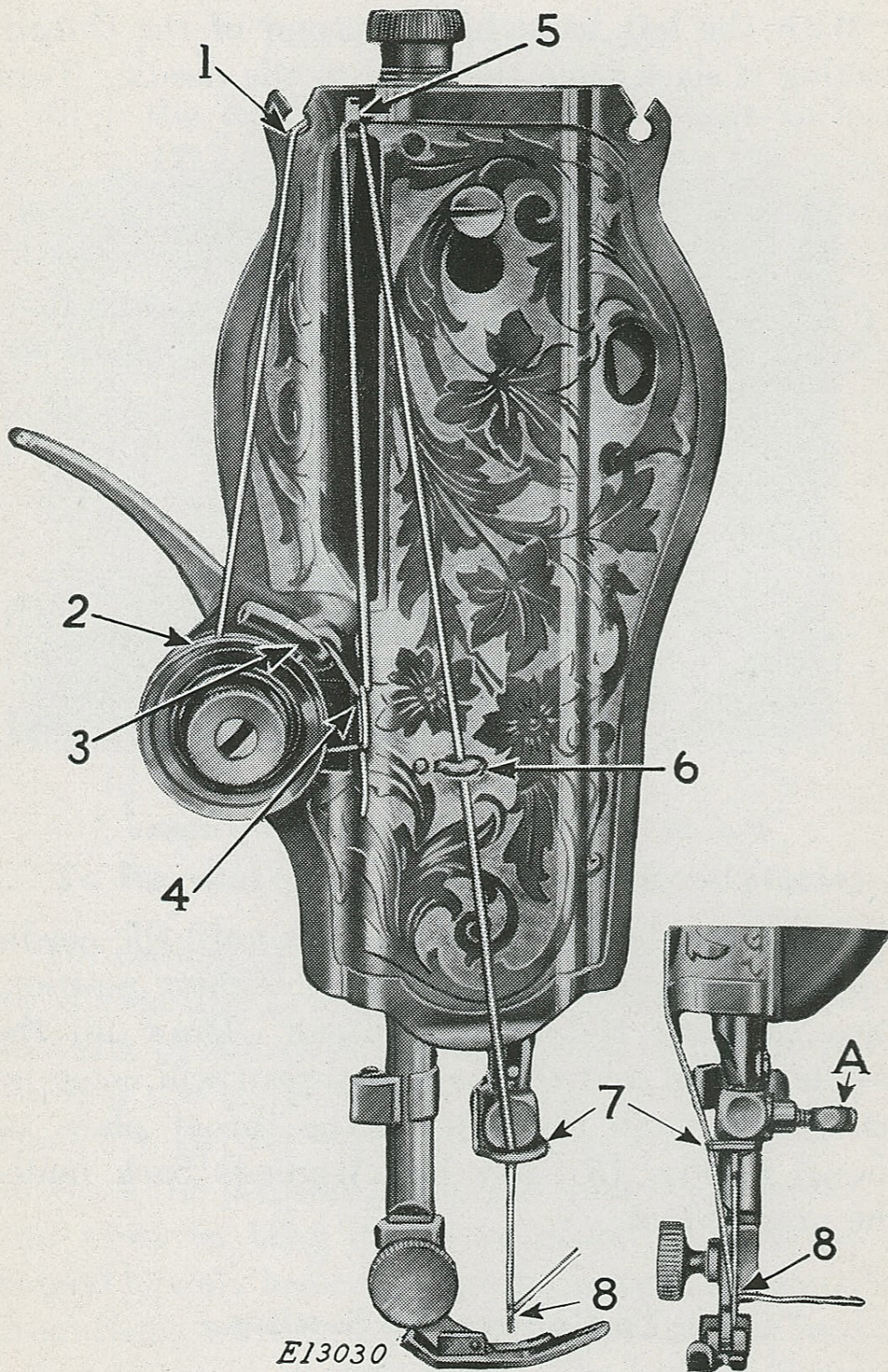

E13030

FIG. 12. UPPER THREADING



### To Prepare for Sewing

With the left hand hold the end of the thread, leaving it slack from the hand to the needle. Turn

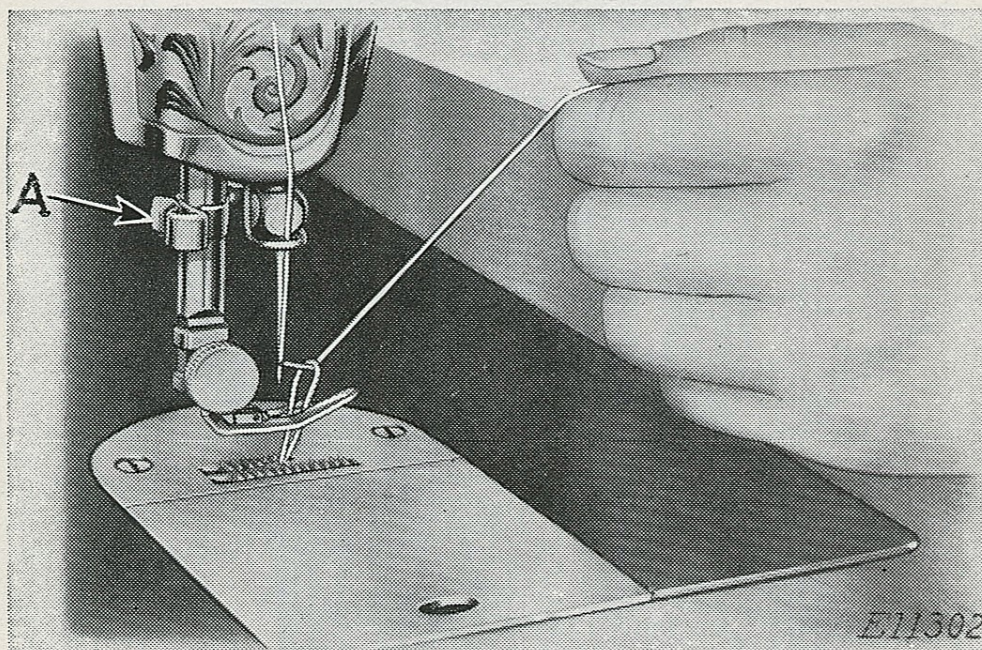

FIG. 13. DRAWING UP THE BOBBIN THREAD

the balance wheel over toward you until the needle moves down and up again to its highest position, thus catching the bobbin thread. Draw up the needle thread and the bobbin thread will come up with it through the hole in the throat plate, as shown in Fig. 13. Lay both threads back under the presser foot.

### To Commence Sewing

Place the material beneath the presser foot, lower the presser foot and commence to sew, turning the balance wheel over toward you.



### **To Remove the Work**

Stop the machine with the thread take-up lever (5, Fig. 12) at its highest position, raise the presser foot and draw the fabric back and to the left, pass the threads over the thread cutter (A, Fig. 13) and pull down lightly to sever them. Leave the ends of the threads under the presser foot.

### **To Turn a Corner**

Stop the machine when the needle is commencing its upward stroke. Raise the presser foot and turn the work as desired, using the needle as a pivot, then lower the presser foot.

### **To Regulate the Pressure on the Material**

For ordinary family sewing, it is seldom necessary to change the pressure on the material. If sewing fine silk or flimsy material, lighten the pressure by turning the thumb screw (A, Fig. 5) on the top of the machine over to the left so that it screws up. To increase the pressure, turn this thumb screw over to the right so that it screws down. The pressure should be only heavy enough to prevent the material from rising with the needle and to enable the feed to move the work along evenly. The heavier the material, the heavier the pressure; the lighter the material, the lighter the pressure.



### To Regulate the Length of Stitch

The machine can be adjusted to make from 6 to 30 stitches to the inch as indicated by the numerals on the stitch indicator plate (C, Fig. 14).

The number of stitches to the inch that the machine is set to make is indicated by the number which is in line with the upper edge of the stitch indicator (B, Fig. 14).

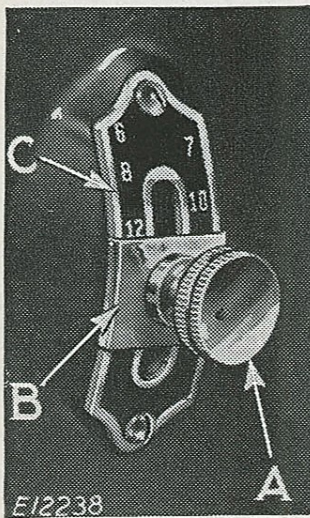

FIG. 14

To change the length of stitch, loosen the thumb screw (A, Fig. 14) and move it up or down until the upper edge of the stitch indicator (B) is in line with the bottom of the number of the desired length of stitch, then tighten thumb screw (A).

### Basting

The longest stitch made by the machine, No. 6 on the stitch indicator plate, is found satisfactory for basting, after loosening the tension on the needle thread so that the stitches may be easily pulled from the material.

Machine basting is firmer and more even than that done by hand in addition to being much quicker.

### To Sew Flannel or Bias Seams

Use a short stitch and as light a tension as possible on the needle thread so as to leave the thread loose enough in the seam to allow the goods to stretch if necessary.



## Tensions

For ordinary stitching, the needle and bobbin threads should be locked in the center of the thickness of the material, thus:



FIG. 15. PERFECT STITCH

If the tension on the needle thread is too tight, or if that on the bobbin thread is too loose, the needle thread will lie straight along the upper surface of the material, thus:

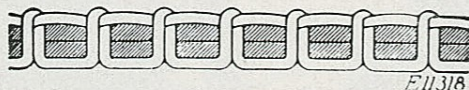

FIG. 16. TIGHT NEEDLE THREAD TENSION

If the tension on the bobbin thread is too tight, or if that on the needle thread is too loose, the bobbin thread will lie straight along the under side of the material, thus:

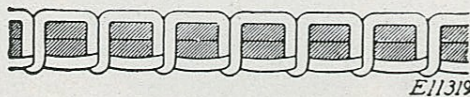

FIG. 17. LOOSE NEEDLE THREAD TENSION

### To Regulate the Tensions

*The tension on the needle thread should be regulated only when the presser foot is down.* Having lowered the presser foot, turn the small thumb nut (F, Fig. 5) at the front of the tension discs over toward you to increase the tension. To decrease the tension, turn the thumb nut over from you.

The tension on the bobbin thread is regulated by the screw (A, Fig. 8) in the bobbin case tension spring. To increase the tension, turn this screw over to the right. To decrease the tension, turn the screw over to the left.

When the tension on the bobbin thread has been once properly adjusted, it is seldom necessary to change it, as a correct stitch can usually be obtained by varying the tension on the needle thread.



### To Oil the Machine

To insure easy running, the machine requires oiling and if used continuously, it should be oiled each

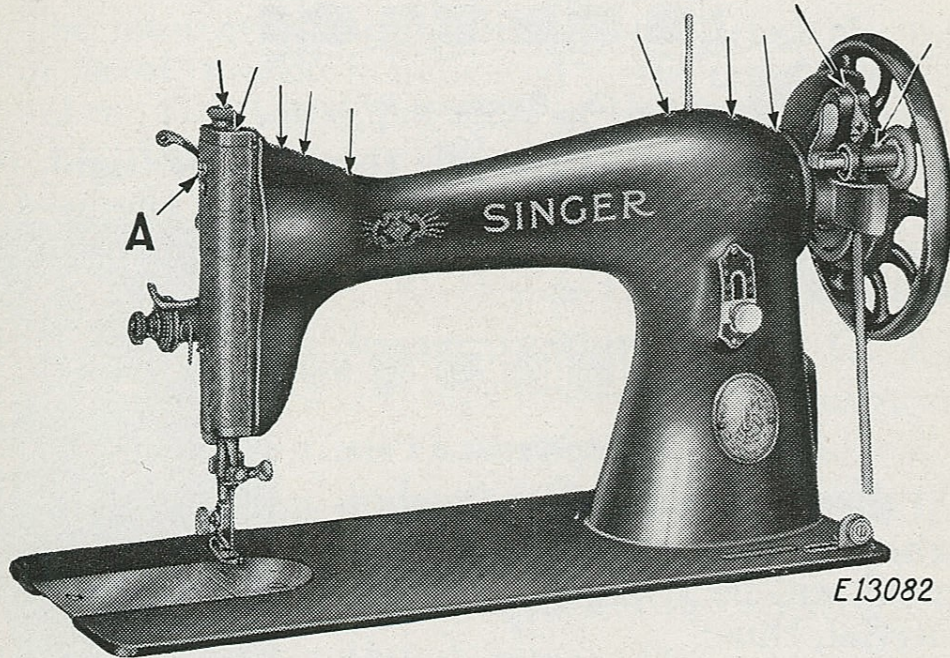

FIG. 18. OILING POINTS AT THE FRONT OF THE MACHINE

day. With moderate use an occasional oiling is sufficient. Oil should be applied at each of the places shown by unlettered arrows in Figs. 18, 19 and 20. One drop of oil at each point is sufficient. Oil holes are provided in the machine for bearings which cannot be directly reached.

Draw to the left the slide in the bed of the machine and apply a few drops of oil to the shuttle race (C, Fig. 10). The slide should then be closed.

Loosen the screw (A, Fig. 18) near the upper end of the face plate, raise the plate and slip it off over the head of the screw; put one drop of oil into each of the oil holes and joints.



On the back of the arm is a round plate or cover, fastened by a thumb screw; loosen the screw, turn the plate upward and fasten by tightening the screw; turn the balance wheel slowly and oil the moving parts inside, then turn the cover down and fasten it as before.

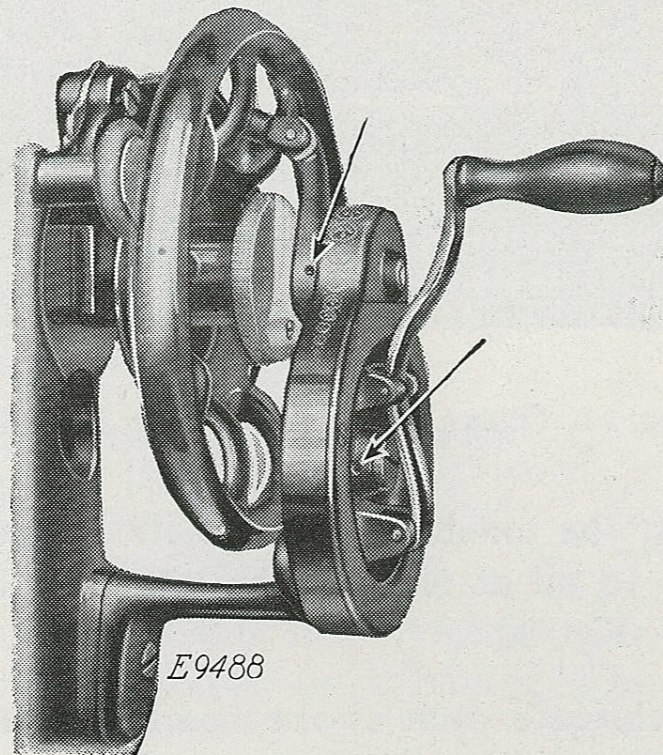

FIG. 19. OILING POINTS IN  
HAND DRIVING ATTACHMENT

Apply a drop of oil at each of the oil holes in the hand driving attachment, as shown by arrows in Fig. 19.



When the machine is used on a foot power stand, to reach the parts underneath the bed of the machine, press the belt shifter to the left and operate the treadle meanwhile until the belt is released,

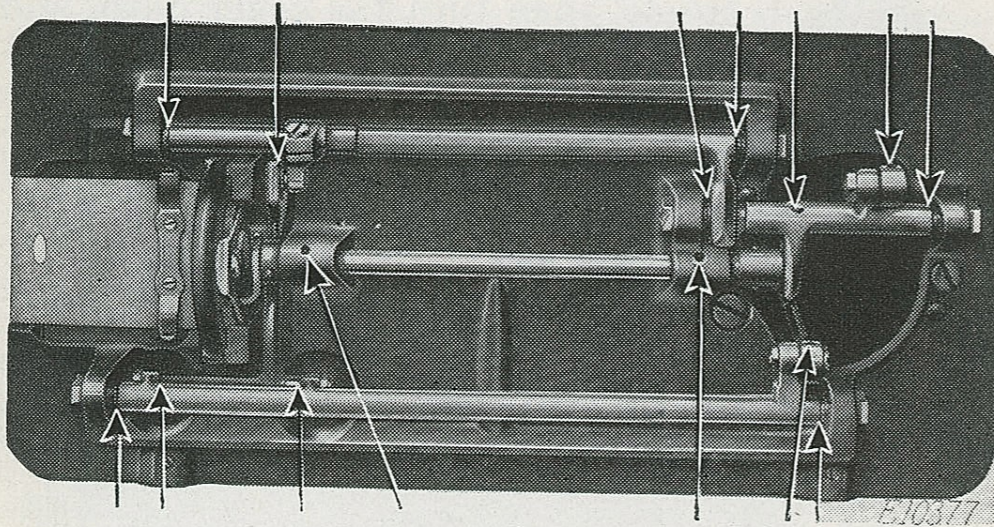

FIG. 20. OILING POINTS IN BASE OF MACHINE

then turn the machine back on its hinges. Apply one drop of oil at each of the places indicated by arrows in Fig. 20.

Also lubricate each of the bearing points in the stand.



## HINTS

**Belt of Foot Power Stand.** See that the belt is not too tight. It should always be tight enough not to slip. If too loose, remove the hook at one end, shorten the belt and rejoin.

**Machine Working Heavily.** If the machine runs hard after standing idle for some time, use a little kerosene in the oiling places, run the machine rapidly, then wipe clean and oil.

**To Avoid Breaking Needles.** See that the presser foot or attachments are securely fastened by the thumb screw. Do not sew heavy seams or very thick goods with too fine a needle. A large needle and thread to correspond should be used on heavy work (see inside cover page at back of book).

See that the needle is not bent, and avoid pulling the material when stitching.

**Breaking of Needle Thread.** If the needle thread breaks it may be caused by:

Improper threading.

Tension being too tight.

The thread being too coarse for size of needle.

The needle being bent, having a blunt point, or being set incorrectly.

**Breaking of Bobbin Thread.** If the bobbin thread breaks it may be caused by:

Improper threading of bobbin case.

Tension being too tight.

**Skipping of stitches.** The needle may not be accurately set into the needle bar or the needle may be blunt or bent. The needle may be too small for the thread in use.

**Free Instruction** for using the machine is gladly given at any Singer Shop.



**Genuine Singer Needles should be used  
in Singer Machines.  
These Needles and their Containers  
are marked with the  
Company's Trade Mark "SIMANCO." 1**

**Needles in Containers marked  
"For Singer Machines"  
are not Singer made needles. 2**



## INSTRUCTIONS FOR USING THE ATTACHMENTS

---

### The Foot Hemmer

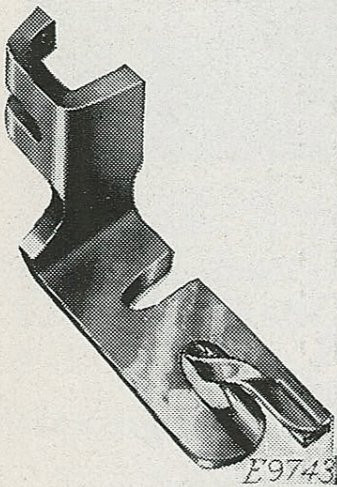

FIG. 21. THE FOOT  
HEMMER

The Foot Hemmer (Fig. 21) is attached to the machine in place of the presser foot. Raise the needle to its highest point, loosen the thumb screw which clamps the presser foot to the presser bar and remove the presser foot. Attach the Foot Hemmer to the bar, taking care to tighten the screw firmly so that the Hemmer will not become loose when the machine is running. Turn the balance wheel slowly to make sure that the needle goes through the center of the needle hole and that the lower thread is properly pulled up.

### How to Start the Hem at the Very Edge

How to start the hem at the very edge of the material is of great importance in learning to use the Hemmer. If the hem is not started at the edge and the material is pulled bias a perfect hem cannot be made.



There are several ways of starting the hem at the edge, but the most practical one is as follows:

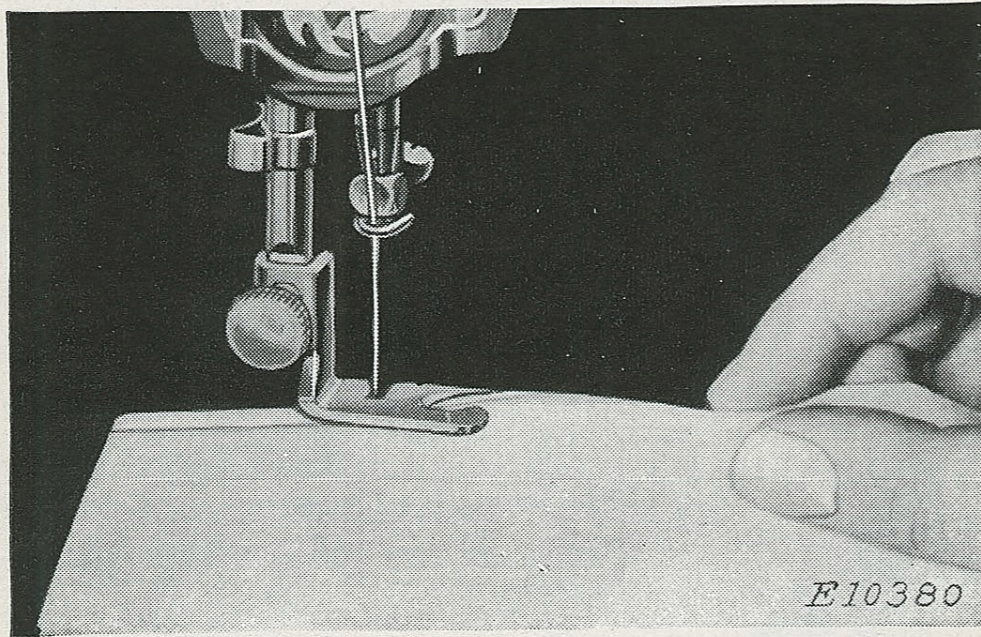

FIG. 22. STARTING A HEM AT THE EDGE

1. Fold over about  $\frac{1}{8}$ " of the edge of the material at the starting point, for a distance of about one inch.
2. Place the material in the Hemmer at an angle leading to the right at a point just beyond the fold.
3. Draw the material toward you through the Hemmer, as shown in Fig. 22, at the same time making the second fold at the very edge. Continue to draw the material through the Hemmer until the edge is just under the needle. Place the upper and lower threads together under the Hemmer foot and assist in starting the hem by slightly pulling the threads from the back as the machine is run.



### Making a Hem with the Foot Hemmer

The same width of material must be kept in the Hemmer at all times. After placing the correct

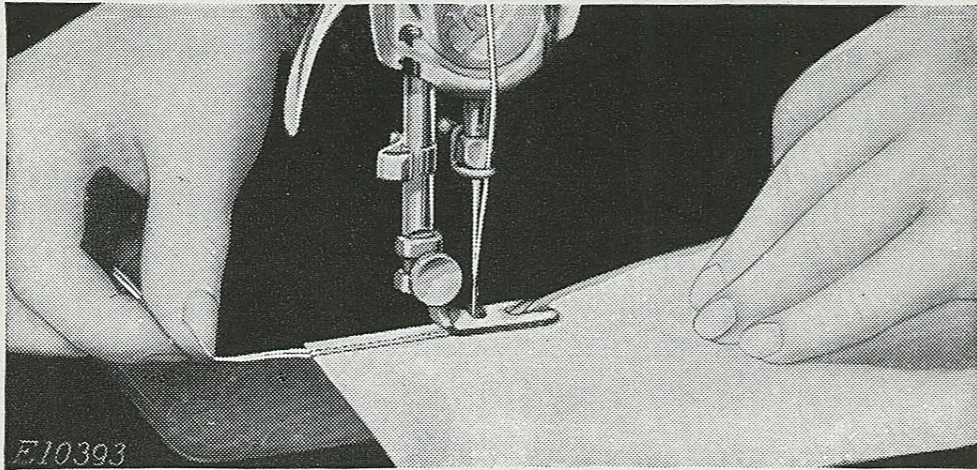

FIG. 23. MAKING A HEM WITH THE FOOT HEMMER

width of material in the Hemmer, hold it in a straight line and you will find it quite easy to make a perfect hem. See Fig. 23.

### Making a Hemmed Seam with the Foot Hemmer

The hemmed seam is very practical to use on underwear, or in fact on any garment where a straight seam is used and where a small double seam would be suitable.

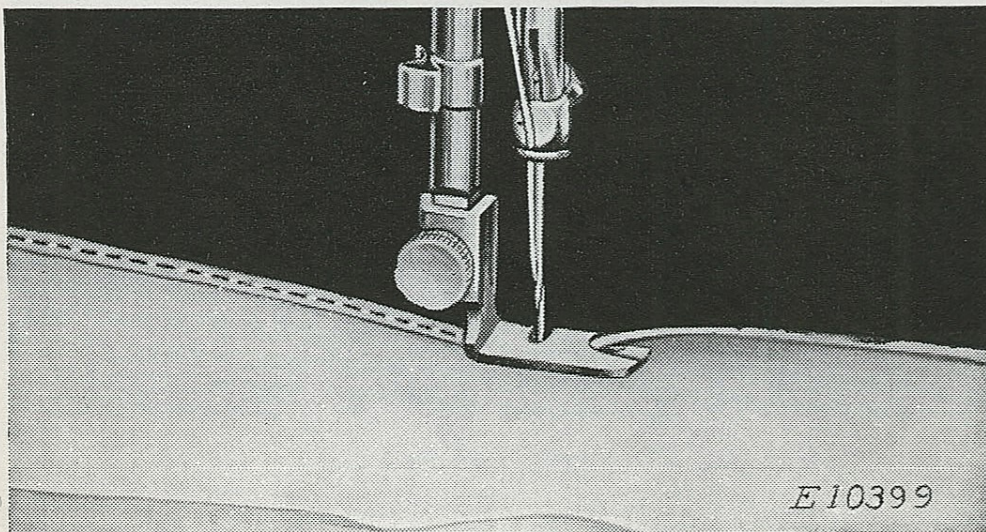

FIG. 24. MAKING A HEMMED SEAM



When using this seam, the garment must first be fitted and the edge of the material trimmed, allowing for about one-eighth inch seam. The two edges are placed together and inserted in the Hemmer in the same manner as a single hem. If the material is bulky, the edge of the upper piece of material may be placed about one-eighth inch in from the edge of the lower piece. See Fig. 24.

The free edge of a hemmed seam may be stitched flat to the garment if desired. First open the work out flat, then place the hem in the scroll of the Hemmer, which acts as a guide, holding the edge of the hem in position while it is being stitched.

If the seam is stitched flat to the garment one row of stitching is visible on the right side.

The hemmed seam may be used on muslin, lawn, percale, organdie or other fine materials where a narrow seam is desirable.

### Hemming and Sewing on Lace in One Operation

Start the hem in the regular way and with the needle holding the hem in position, raise the presser

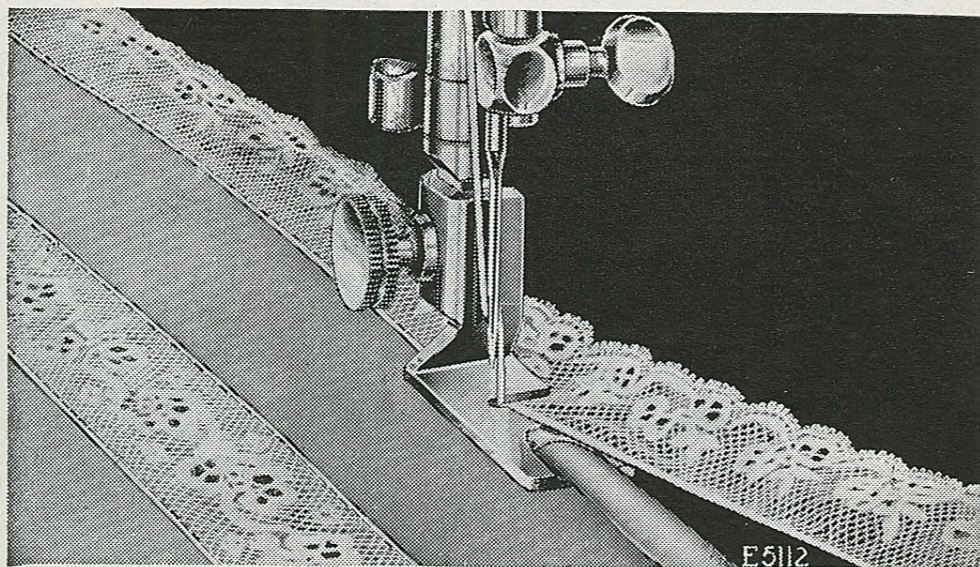

FIG. 25. HEMMING AND SEWING ON LACE

bar sufficiently to allow the edge of the lace to be slipped in under the Foot Hemmer, at the same time



bringing it up through the slot at the right of the Hemmer. See Fig. 25. Lower the bar, turn the balance wheel and catch the edge of the lace with the needle. Guide the hem with the right hand and the lace with the left. Care should be taken not to stretch the lace as it is being fed into the Hemmer.

It is not practical to sew gathered lace on with the Foot Hemmer, as the fulled lace catches in the Hemmer slot.

A very attractive way of applying lace so that the stitching of the hem is not visible is to start the hem in the regular way, slipping the lace in from the left as you would the second piece of material when making a hemmed seam.

### ADJUSTABLE HEMMER—Hemming

Remove the presser foot and attach the adjustable hemmer in its place, as shown in Fig. 26. This

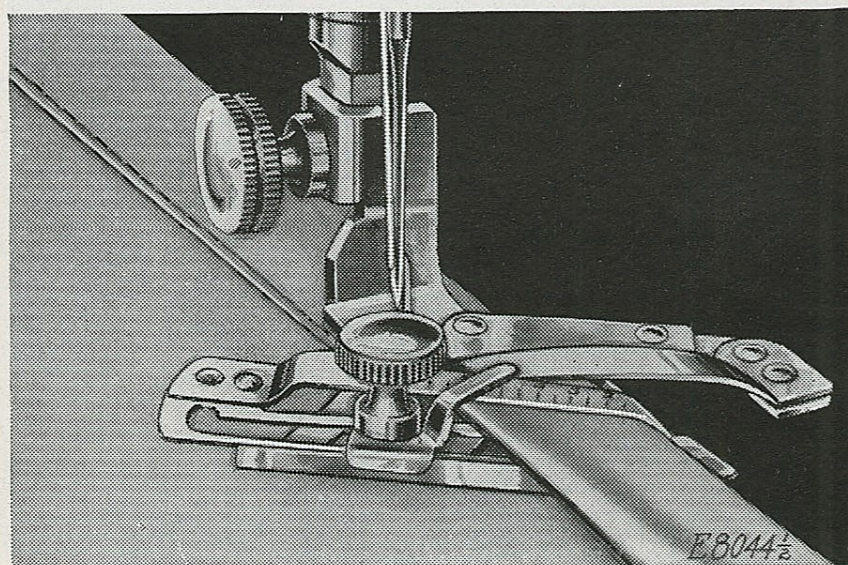

FIG. 26

hemmer will turn hems from  $\frac{3}{16}$  inch to  $\frac{15}{16}$  inch wide. The adjustment is made by loosening the thumb screw on the hemmer and moving the scale to the



right or left until the hem turned is of the desired width. Place the cloth under the hemmer and draw the edge toward the left under the scale, as shown in Fig. 26. Draw the edge of the cloth back and forth until the hem is formed, stopping with the end under the needle. Lower the presser bar and commence to sew, being careful to so guide the cloth as to keep the hemmer full.

### ADJUSTABLE HEMMER—Wide Hemming

To make a hem more than  $\frac{15}{16}$  inch wide, loosen the thumb screw in the hemmer and move the scale

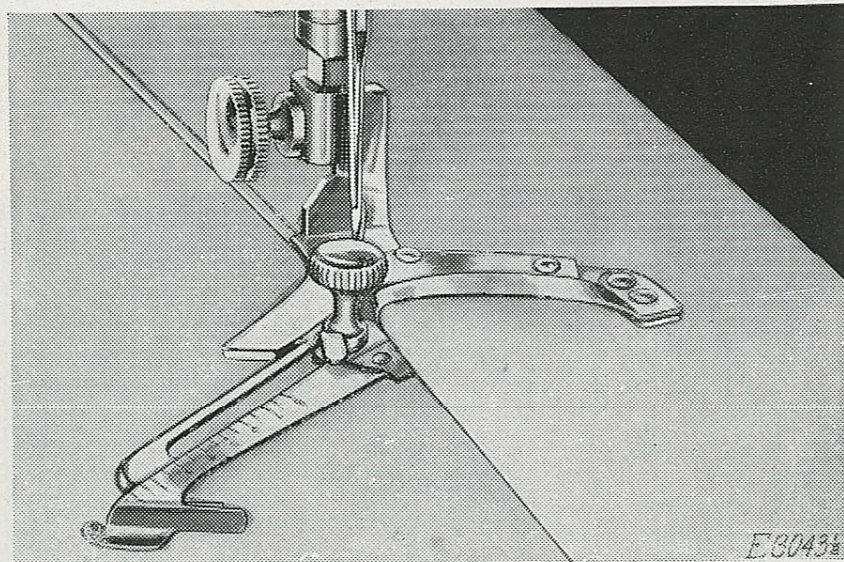

FIG. 27

to the right as far as it will go, then swing it toward you as shown in Fig. 27 and tighten the thumb screw. Fold and crease down a hem of the desired width; pass the fold under the extension at the right of the hemmer, and the edge into the folder as shown in Fig. 27, and proceed to stitch the hem.



## Attaching the Binder to the Machine

Raise the needle to its highest point and remove the presser foot from the machine by loosening the

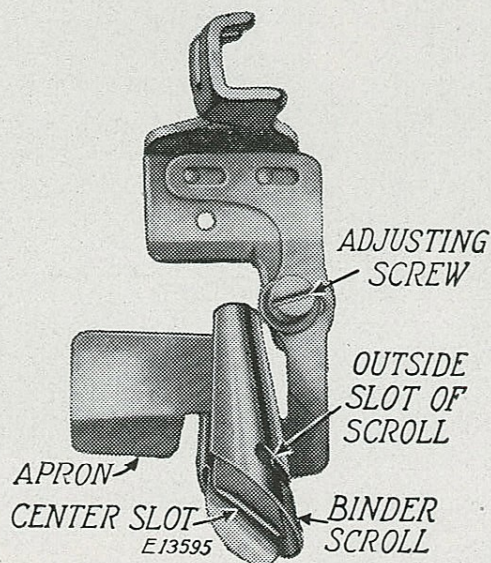

FIG. 28

thumb screw which holds it in place. Compare the foot of the Binder and the presser foot and you will see that they are attached to the machine in the same manner. Attach the Binder to the presser bar. Turn the balance wheel slowly toward you to make sure that the Binder is properly attached to the bar and that the needle goes through the center of the needle hole.

### Inserting the Binding in the Binder

Cut the binding to a long point to left, as shown. Insert the pointed end in the binder scroll (Fig. 30) until the pointed end comes through the lower end of the scroll.

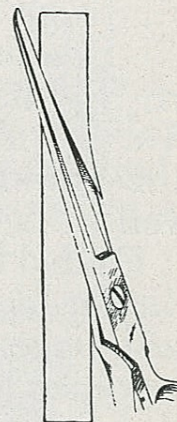

FIG. 29  
CUTTING POINT  
ON BINDING



Pull the binding through under the presser foot before starting to sew. Note that as the binding passes through the scroll of the Binder the edges are turned in.

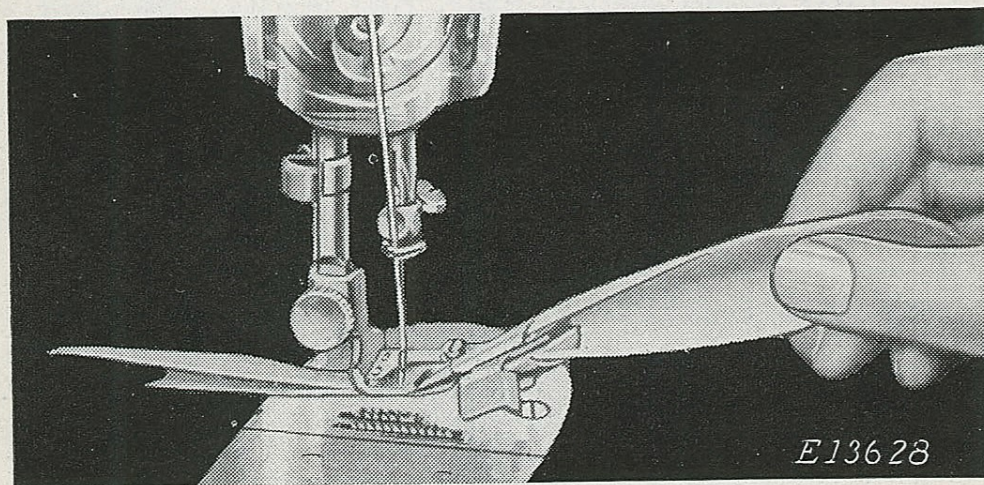

FIG. 30. INSERTING BINDING IN BINDER

### Binding May be Purchased Cut and Folded for Use with the Binder

Folded bias binding may be purchased for use with the Binder. The binding comes in a variety of materials and colors. Folded bindings for use with the Binder must measure  $\frac{1}{2}$ " in width. The No. 5 width in standard brands usually measures  $\frac{1}{2}$ ", but it is always well to be sure of this before purchasing.

Folded binding is inserted in the outside slot of the Binder, as shown in Fig. 31. The Binder is adjusted and operated in the same manner as when using unfolded binding. One-half inch braid or ribbon may be used in the same manner.

A binding inserted in the outside slot of the Binder will be turned only once. It is therefore necessary to have finished edges when using binding in this slot.

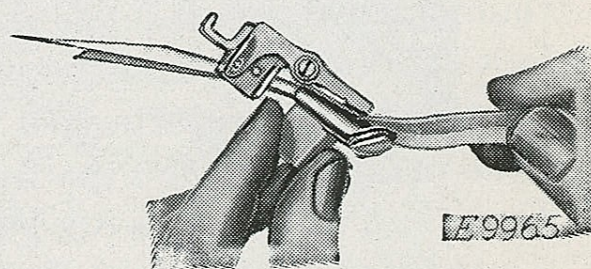

FIG. 31. INSERT FOLDED BINDING IN OUTSIDE SLOT



## The Adjustment and Operation of the Binder

The edge to be bound should be held well within the center slot of the scroll (A, Fig. 32). If the

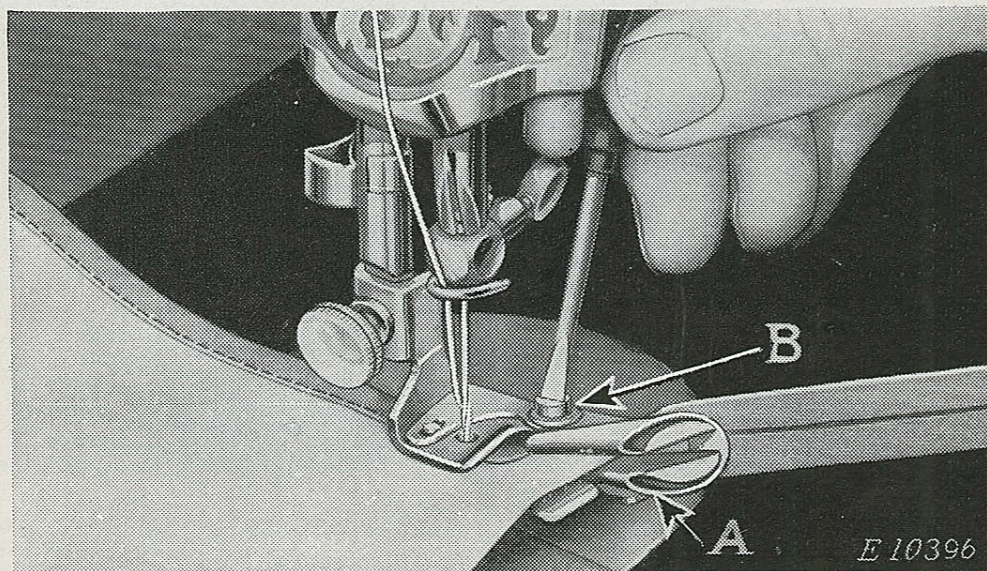

FIG. 32. ADJUSTING THE BINDER

material is allowed to slip away from the scroll when near the needle, the edge will not be caught in the binding. With a little practice it is quite easy to hold the edge in the scroll.

Various materials and conditions require different adjustments of the Binder to bring the stitching close to the edge. A wider adjustment of the Binder is required when binding curves than is necessary when binding a straight edge.

To adjust the Binder for stitching, loosen screw (B, Fig. 32) and move scroll to the right for a narrower adjustment and to the left for a wider adjustment. Care should be taken to see that the screw is well tightened after making an adjustment. To become perfectly familiar with the adjustment of the Binder, practice is necessary.



## Binding Outside Curves

Practice is required to bind a curved edge properly. The edge to be bound must be allowed to pass freely

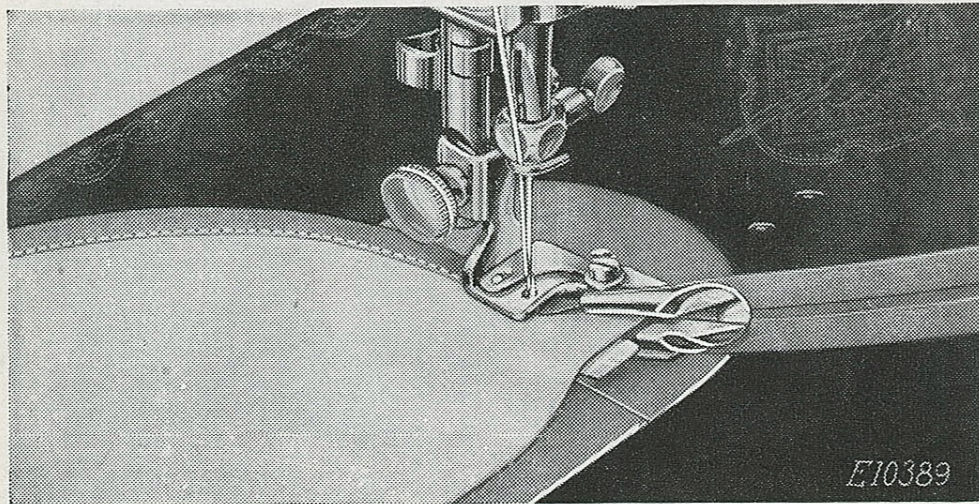

FIG. 33. BINDING AN OUTSIDE CURVE

through the scroll and should not be crowded against the wall of it. Guiding should be from the back

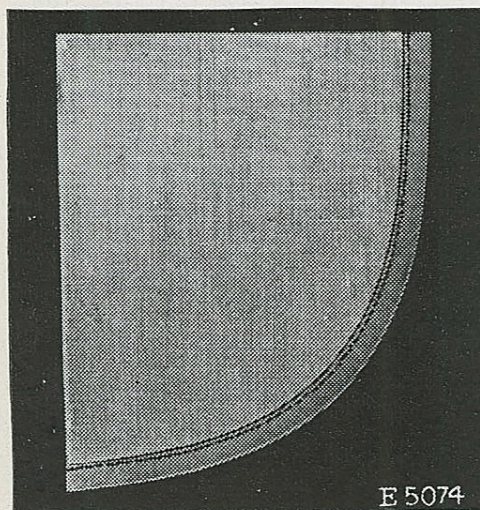

FIG. 34. SAMPLE OF OUTSIDE CURVE

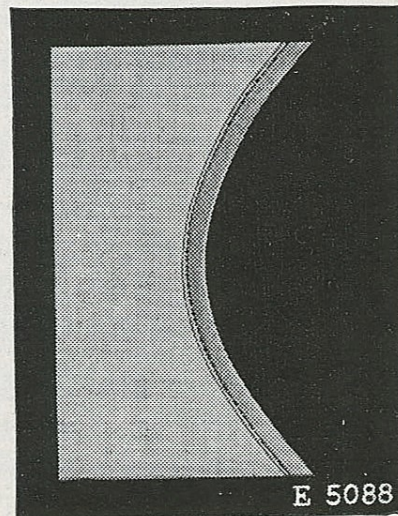

FIG. 35. SAMPLE OF INSIDE CURVE



of the Binder and to the left, allowing unfinished edges to swing naturally into the scroll of the Binder.

Never pull the binding as it feeds through the Binder, as bias material is very easily stretched and will be too narrow when it reaches the needle. When this occurs the edges will not be turned.

When binding a curved edge (see Fig. 33), turn the material only as fast as the machine sews. It is not possible to hold the material in the entire length of the scroll when binding a small curve.

Do not push the material in too fast, as the edge will then become puckered, and do not stretch the material or the curve will not be the proper shape when finished. If the stitching does not catch the edge of the binding, the scroll should be adjusted a trifle to the left.

### **Binding Inside Curves**

It will be necessary to practice binding an inside curve on various kinds of material, as this curve is found on nearly all garments which may be finished with a bound edge.

When binding an inside curve with the Binder, straighten out the edge as it is being fed into the attachment. When doing this, care should be taken not to stretch the edge of the material.

If the material is soft, like batiste or crepe de chine, add a row of machine stitching close to the edge of the curve before binding.



### Applying a French Fold to a Curve

A French fold is applied by placing the material under the attachment and stitching the binding in

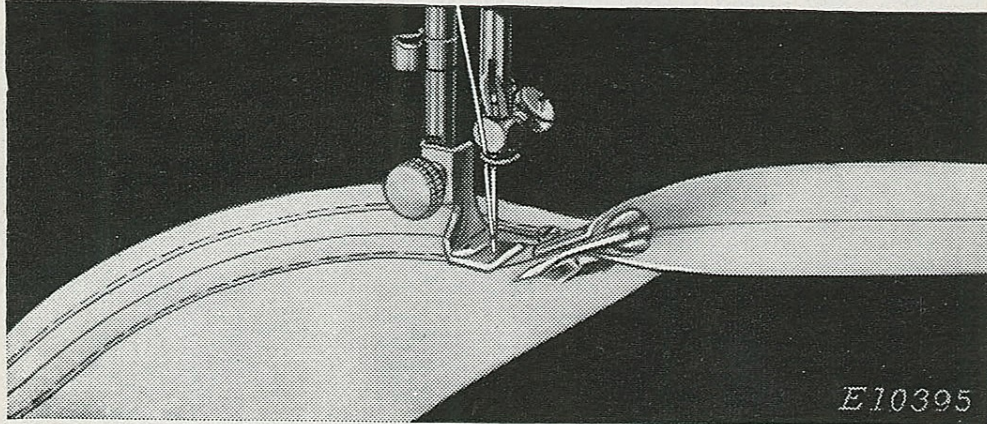

FIG. 36. APPLYING FRENCH FOLDS

position as shown in Fig. 36. A line made by basting or with chalk or pencil may be used as a guide in applying rows where wanted.

### DAINTY WAYS TO USE THE TUCKER

Tucking is the natural trimming for fine materials such as lawn, organdie, batiste, etc., and may be made without basting in any width from a fine pin tuck to one inch wide when using the Singer Tucker. The Tucker gauges the width of the tuck and while one tuck is being stitched, the mark for the next tuck is being made.

It is so simple to make tucks in this way that it is a joy to plan garments with this fascinating trimming. Then, too, such trimmings may be made without extra cost. The fashion magazines always give numerous suggestions for tucking various garments. The following pages will explain the adjusting and operating of this time-saving attachment.



## The Parts of the Tucker and Their Uses

Select the Tucker from the box of attachments, compare it with Fig. 37 and note the names and uses of the various parts, as follows:

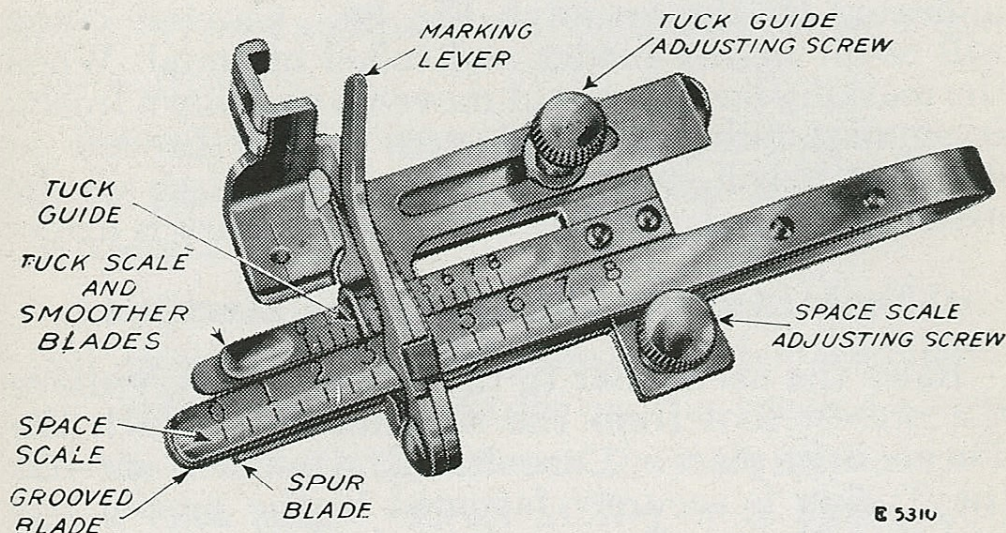

FIG. 37. THE TUCKER AND ITS WORKING PARTS

**The Tuck Guide**, which is adjustable and may be set for any desired width of tuck.

**The Tuck Scale**, containing figures which indicate different widths of tucks. The tuck scale also acts as a smoother blade, keeping the tucks of uniform width.

**The Tuck Guide Adjusting Screw**, by means of which the tuck guide may be set at any point on the tuck scale.

**The Space Scale**, containing figures on the upper blade which indicate the width of the space between tucks. The middle or **grooved blade** contains a groove into which the material is pressed by the **spur** at the end of the lower or **spur blade**, thus marking the goods for the folding of the next tuck.

**The Space Scale Adjusting Screw**, by means of which the space scale may be set at any desired point.

**The Marking Lever**, which presses on the grooved blade, marking the material as it passes between the grooved and spur blades.



### Where to Oil the Tucker

The only place on the Tucker that requires oiling is the stud on which the marking lever works. One drop of oil occasionally is sufficient at the point indicated by the arrow in Fig. 39. Careless oiling will result in oily blades and soiled material. When the marking lever does not move up and down freely, it requires oiling. If neglected, it may become so dry that it will stay down and cause a drag on the material instead of lifting freely as the mark is made.

### To Attach the Tucker to the Machine

Raise the needle bar to the highest point, remove the presser foot from the machine and attach the Tucker in its place. Care should be taken to see that the Tucker is securely fastened to the presser bar and that the needle goes through the center of the needle hole. Note the position of the marking lever, making sure that it is in the lower position and that the needle clamp works on it as the machine sews.

### How to Adjust the Scales on the Tucker

The width of the tucks and the space between them is determined by the adjustment of the scales. Adjustment for width of tuck is made by loosening the tuck guide adjusting screw, which allows you to move the tuck guide to the desired figure on the tuck scale. The tuck guide should be set just over the figure you wish to use. The adjusting screw should always be well tightened.

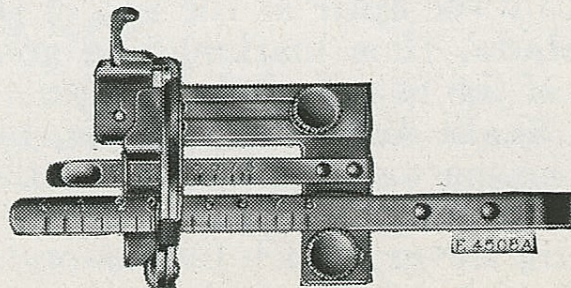

FIG. 38. TUCKER SET AT PIN TUCK AND 2 SPACE



To adjust the width of space between the tucks loosen the space scale adjusting screw and move the space scale until the desired figure is directly in a line with the center of the needle hole. You will find a line in front and back of the needle hole to indicate the center.

Before starting to sew, tighten the screw firmly to prevent the scale shifting when the Tucker is in operation.

The figures on the tuck scale indicate the width of tuck in eighths of an inch, the marks between figures are sixteenths. The marks on the space scale are double the width of those on the tuck scale, so that when both scales are set at the same figure, blind tucks without spaces between them are made.

To make space between tucks, first set the tuck scale, then move the space scale to the same number and as much farther to the left as you wish to have space. Each number on the space scale represents one-quarter of an inch and each mark between numbers one-eighth of an inch.

Use the table below to assist you in setting the Tucker.

	TUCK GUIDE	SPACE SCALE
$\frac{1}{8}$ " tucks with no space	1	1
$\frac{1}{8}$ " " " $\frac{1}{8}$ " "	1	$1\frac{1}{2}$
$\frac{1}{4}$ " " " no "	2	2
$\frac{1}{4}$ " " " $\frac{1}{4}$ " "	2	3
$\frac{1}{2}$ " " " no "	4	4
$\frac{1}{2}$ " " " $\frac{1}{2}$ " "	4	6
1" " " no "	8	8

Note Fig. 38, showing Tucker set at a pin tuck and 2 for space.



### Where to Insert the Material to be Tucked

Fold and crease the first tuck for its entire length by hand, insert it in the Tucker from the left, placing

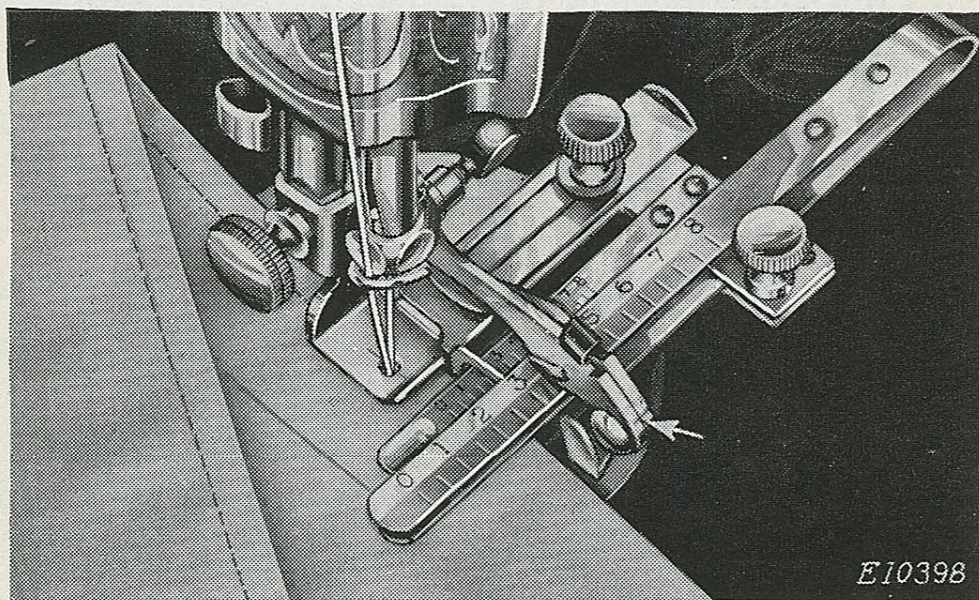

FIG. 39. PROPER POSITION OF MATERIAL IN TUCKER

it between the grooved blade and the spur blade of the space scale, and between the two blades of the tuck scale. See Fig. 39.

Care should be taken to see that the material is placed far enough in the Tucker to feed against the tuck guide. Draw the material towards you until the edge is directly under the needle. Lower the presser bar and sew. You will note that the Tucker is making a mark for the next tuck.

When the first tuck is finished, fold the material on the mark made by the spur during the sewing of the first tuck and insert the folded edge in the Tucker. It is most important to see that the first tuck is against the inside of the spur. After lowering the presser bar, raise the material slightly and adjust it until the folded edge is just touching the guide and the preceding tuck is against the spur. This insures even tucks.



## RUFFLER

Lines 1, 2, 3, 4 and 5 shown in Fig. 40 indicate where the material is to be placed for various operations, as follows:

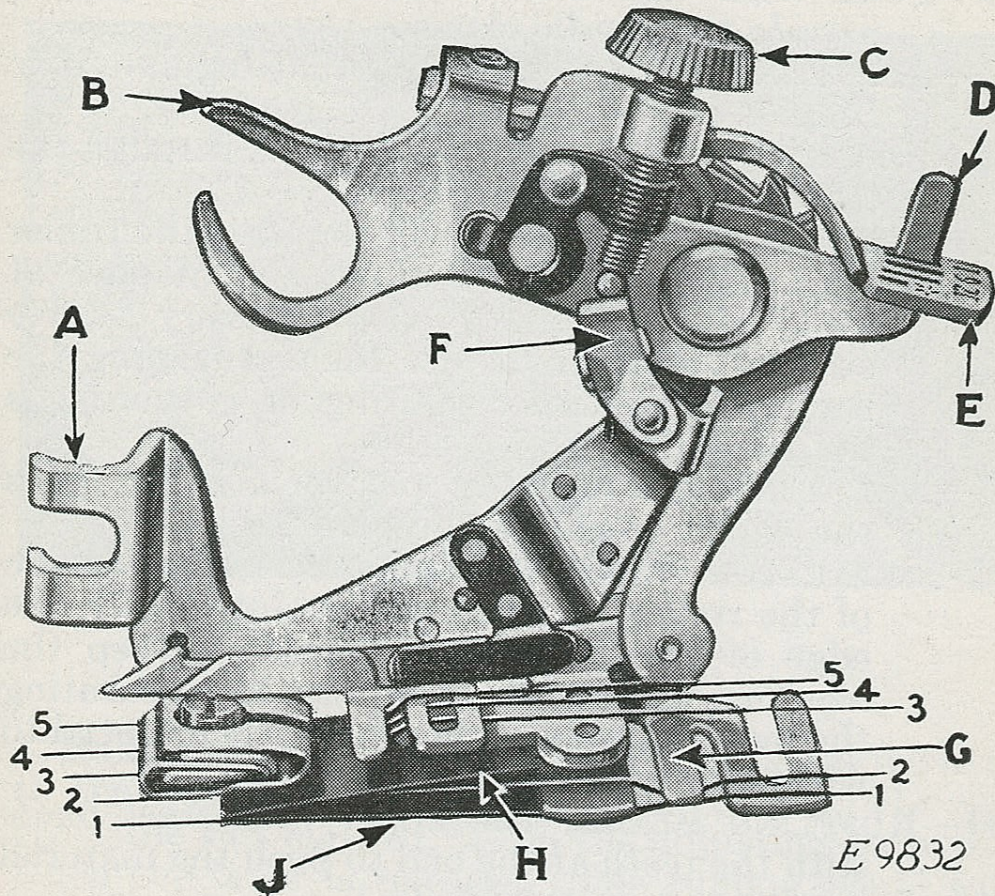

FIG. 40. THE RUFFLER AND ITS PARTS

**Line 1**—the correct position for the material to which the ruffled material is applied.

**Line 2**—material to be ruffled.

**Line 3**—the facing for the ruffle.

**Line 4**—the strip of piping material.

**Line 5**—the edge to be piped.

Refer to Fig. 40 when inserting the material in the ruffler.



The names and uses of the principal parts of the ruffler are as follows:

(SEE REFERENCES IN FIG. 40)

- A—FOOT**—the part by which the ruffler is attached to the presser bar.
- B—FORK ARM**—the section that must be placed astride the needle clamp.
- C—ADJUSTING SCREW**—the screw that regulates the fullness of the gather.
- D—PROJECTION**—the part that projects through the slots in the adjusting lever.
- E—ADJUSTING LEVER**—the lever that sets the ruffler for gathering or for making a plait once at every six stitches or once at every twelve stitches, as desired; also for disengaging the ruffler, when either plaiting or gathering is not desired.
- F—ADJUSTING FINGER**—the part which regulates the width or size of the plaits.
- G—SEPARATOR GUIDE**—the guide on the underside of the ruffler, containing slots into which the edge of the material is placed to keep the heading of the ruffle even; also for separating the material to be ruffled from the material to which the ruffle is to be attached.
- H—RUFFLING BLADE**—the upper blue steel blade with the teeth at the end to push the material in plaits up to the needle.
- J—SEPARATOR BLADE**—the lower blue steel blade without teeth, which prevents the teeth of the ruffling blade coming into contact with the feed of the machine, or the material to which ruffle or plaiting is to be applied.

### To Attach the Ruffler to the Machine

Raise the needle bar to its highest point and remove the presser foot. Attach the ruffler foot (A, Fig. 40) to the presser bar by means of the thumb screw, at the same time placing the fork arm (B, Fig. 40) astride the needle clamp as shown in Fig. 41.



## To Adjust the Ruffler for Gathering

The adjusting finger (F, Fig. 41) is not intended for gathering and should be moved forward or away from the needle as shown in Fig. 41.

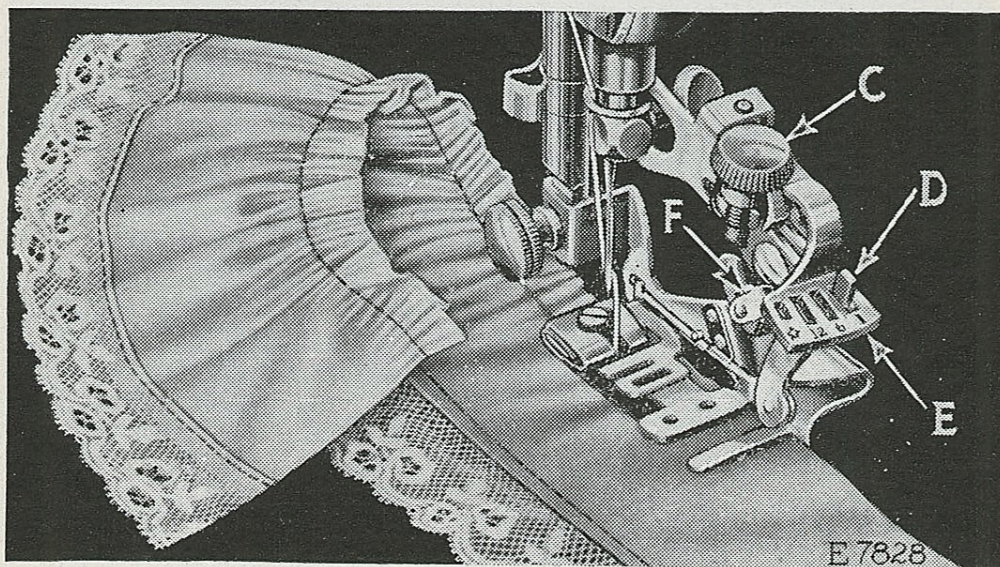

FIG. 41

Raise the adjusting lever (E, Fig. 41) and move it to the left so that the projection (D, Fig. 41) will enter the slot marked "1" in the adjusting lever (E) when the lever is released. The ruffling blade will then move forward and back once at every stitch. Insert the material to be ruffled between the two blue blades, following the line 2 in Fig. 40. Draw the material slightly back of the needle, lower the presser bar and commence to sew.

To make fine gathering, shorten the stroke of the ruffling blade by turning the adjusting screw (C, Fig. 41) upward; also shorten the stitch. To make full gathering, lengthen the stroke of the ruffling blade by turning the adjusting screw (C) downward; also lengthen the stitch. By varying these adjustments, many pleasing varieties of work can be accomplished.



### To Make a Ruffle and Sew it to a Garment in One Operation

Insert the material to be ruffled between the two blue blades, as shown in Fig. 42, following the line

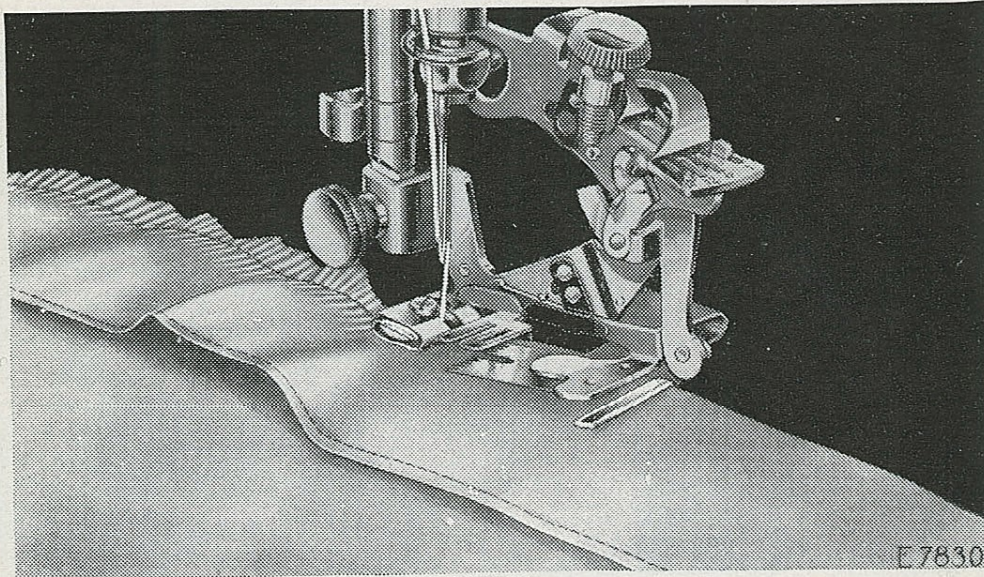

FIG. 42

2, in Fig. 40. Place the garment to which the ruffle is to be attached, under the separator blade, following the line 1, in Fig. 40. Proceed the same as for gathering.

The edge of the ruffled seam can be bound by using the binder.

### To Ruffle and Sew on a Facing in One Operation

Insert the material to be ruffled between the two blue blades, following the line 2, in Fig. 40. Place the garment to which the ruffle is to be attached, under the separator blade, following the line 1, in Fig. 40. Place the material for the facing over the upper blue blade, as shown in Fig. 43, following the line 3, in Fig. 40. The facing may be straight or bias material. If the facing is to be on the right side of the garment, place the garment and



the ruffle so that the wrong sides are together. If the facing is to be on the wrong side, place the right sides of the garment and the ruffle together.

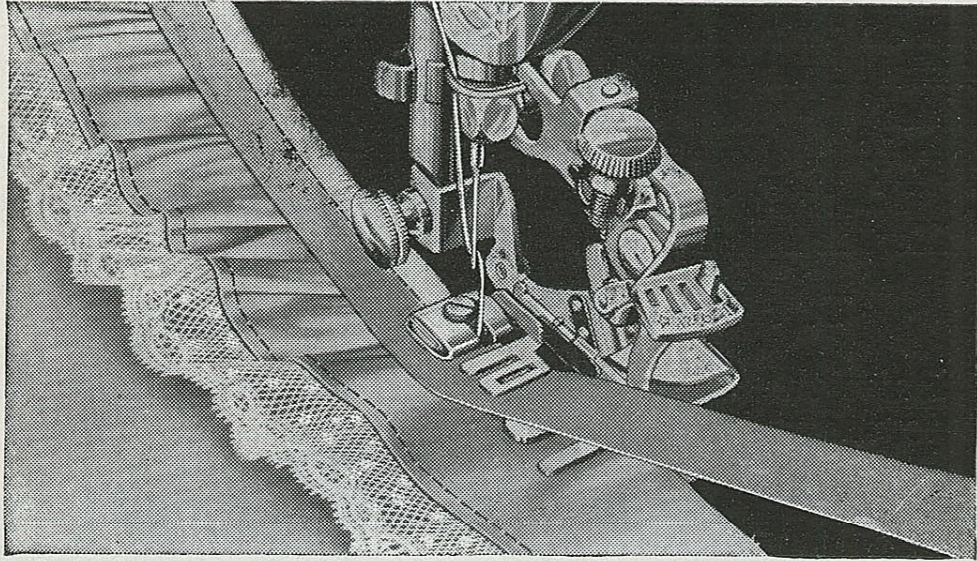

FIG. 43

### Piping a Ruffle

Insert the material to be ruffled between the two blue blades, following the line 2, in Fig. 40. This

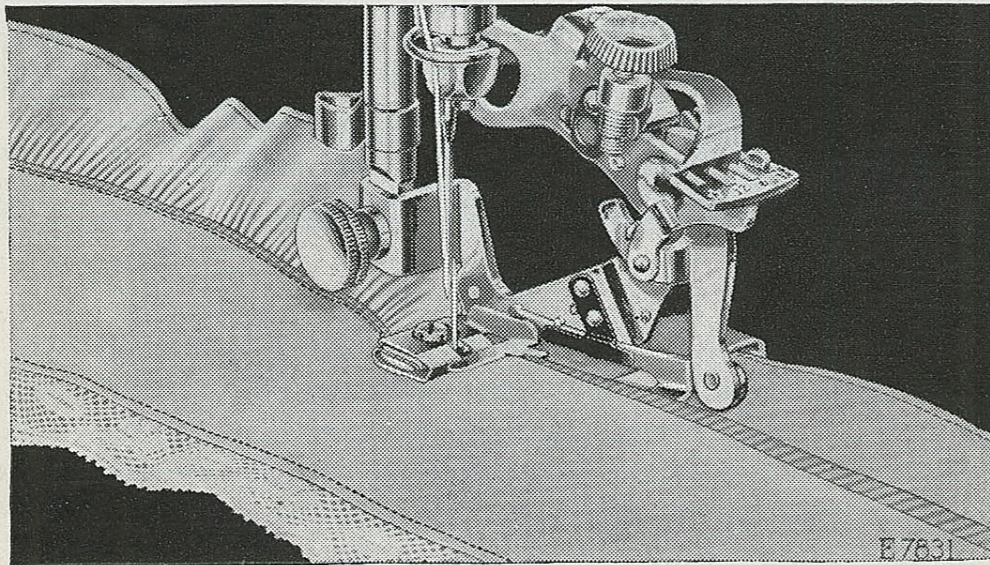

FIG. 44

material must not be over  $1\frac{1}{4}$  inches wide, as it is carried through the ruffler with the finished



edge of the ruffle to the right of the attachment as shown in Fig. 44.

The material for piping must measure about  $\frac{1}{4}$  inch wide when folded in the center and is usually cut on the bias. Place the piping material in the ruffler, following the line 4, in Fig. 40, with the folded edge of the piping to the right. The material to which the piping and ruffling are to be sewn should be folded on the edge and inserted in the ruffler, following the line 5, in Fig. 40.

### To Adjust the Ruffler for Plaiting

Raise the adjusting lever (E, Fig. 45) and move it to the right so that the projection (D, Fig. 45)

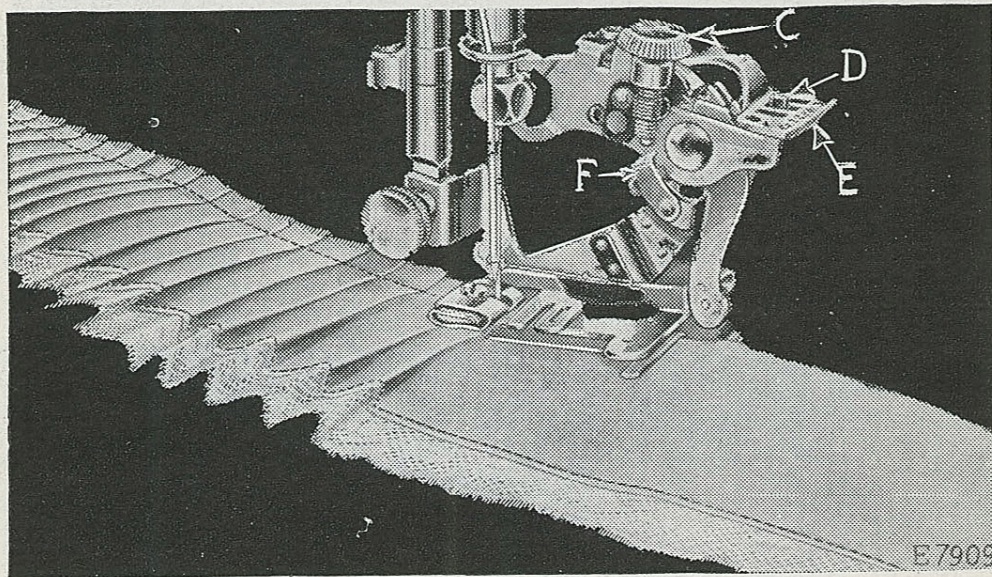

FIG. 45

will enter the slot marked "6" in the adjusting lever when the lever is released. The ruffling blade will then move forward and back once at every six stitches. To adjust the ruffling blade to make a plait once at every twelve stitches, place the adjusting lever (E, Fig. 45) so that the projection (D) enters the slot marked "12" in the adjusting lever. Insert the material to be plaited between the two blue blades, following the line 2 (Fig. 40). The size or width of plaits is regulated by the adjusting screw



(C, Fig. 45) and the adjusting finger (F, Fig. 45). To make a wider plait, move the adjusting finger (F) back or toward the needle and turn the adjusting screw (C) downward. To make a smaller plait, turn the adjusting screw (C) upward. The distance between plaits is regulated by the length of stitch.

### To Adjust the Ruffler for Group Plaiting and Gathering

The ruffler can be adjusted for group plaiting by lifting the adjusting lever (E, Fig. 46) and moving

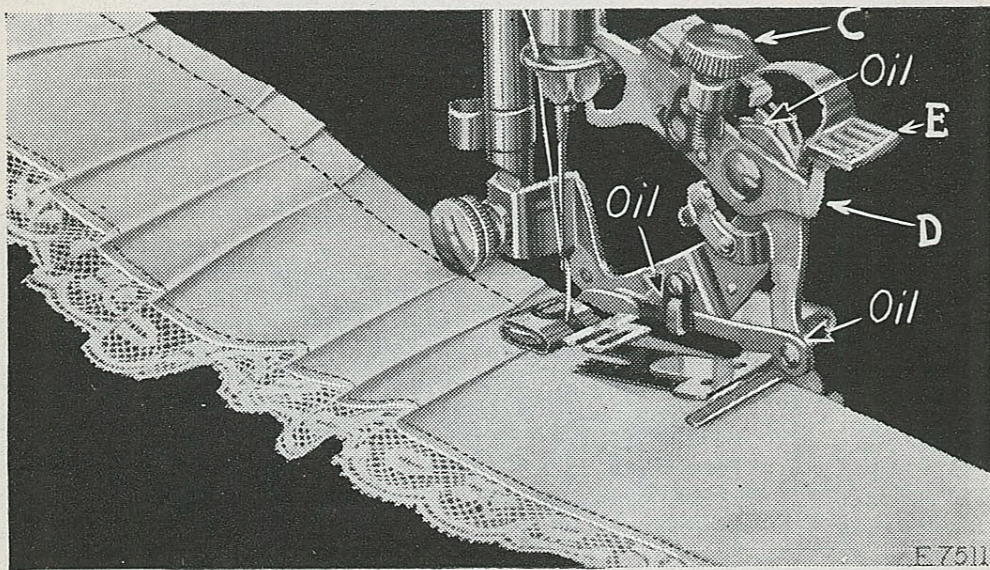

FIG. 46

it to the right so that the top of the projection (D, Fig. 46) enters the small slot indicated by the star on the adjusting lever. This should be done at the points where you wish to make the space between the plaits. The ruffler will then stop and plain stitching will be made. When the desired space has been made, adjust the lever (E) so that the projection (D) enters either the slot marked "6" or the slot marked "12". By alternately making groups of plaits and plain spaces, as shown in Fig. 46, very attractive work can be produced.



### To Oil the Ruffler

Occasionally apply a drop of oil to the working parts of the ruffler at each of the places indicated by arrows in Fig. 46. After oiling, operate the ruffler on a waste piece of material to prevent the oil soiling the work. If the ruffler does not plait evenly, a drop of oil may remedy the trouble.

### To Use the Cloth Guide

To insure accurate guiding of the work when sewing close to the edge of the goods, the cloth

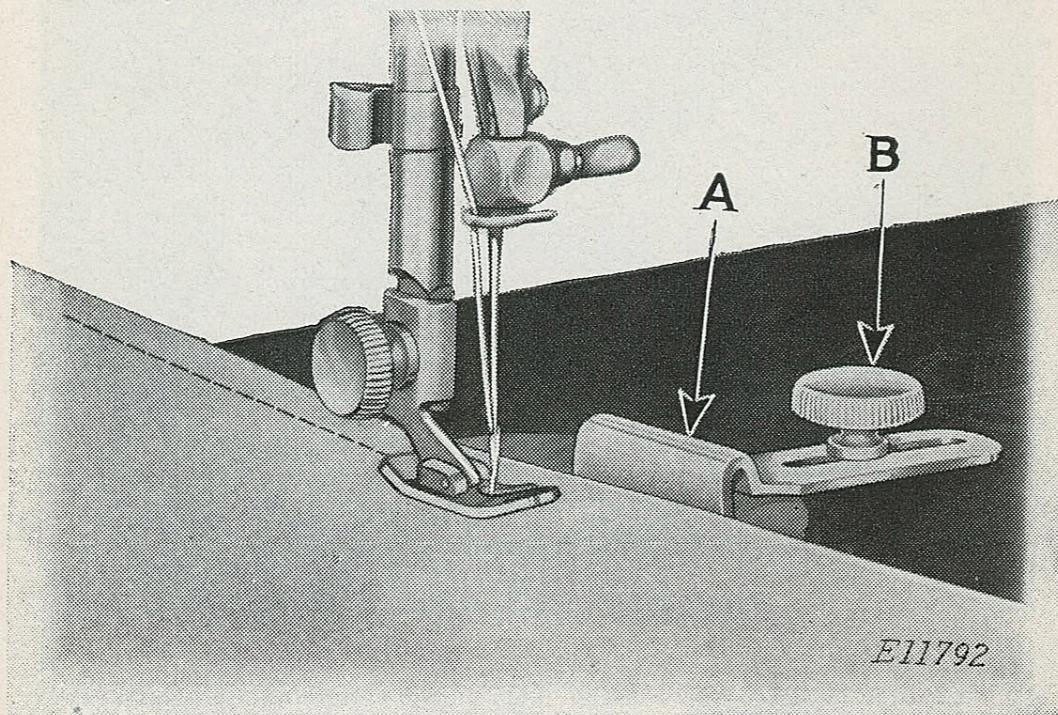

FIG. 47

guide (A, Fig. 47) should be used. Fasten the cloth guide to the bed of the machine by means of the clamping thumb screw (B, Fig. 47), inserting the thumb screw into either one of the two screw holes in the bed of the machine. The cloth guide can be adjusted to bring the edge of the goods as close to the line of stitching as desired.



## RELATIVE SIZES OF NEEDLES AND THREAD

(Class and Variety of Needles Used, 15x1)

SIZES OF NEEDLES	CLASSES OF WORK	SIZES OF COTTON, SILK OR LINEN THREAD
9	Georgette, chiffon, light weight rayon, fine dimity, lawn, batiste, and other featherweight or sheer fabrics. For infants' clothes and for dainty lingerie; also fine lace and all delicate or gossamer fabrics.	100 to 150 Cotton OO & OOO Silk Twist
11	All medium, light weight summertime fabrics. For children's clothes, dainty house dresses and aprons, glass curtains.	80 to 100 Cotton O Silk Twist
14	Light weight woolens, firm dress silks and cottons, draperies and fabric furnishings. For smocks and men's fine shirts. For general household sewing; for fine quilting.	60 to 80 Cotton A & B Silk Twist
16	Heavy cretonne, madras, muslin and quilts. For stitching aprons and men's work shirts. For making buttonholes.	40 to 60 Cotton C Silk Twist
18	Bed ticking, awnings, porch furniture covers, boys' duck suits.	30 to 40 Cotton D Silk Twist
19	Heavy weaves of coating, suiting, ticking, sacking, tarpaulin, duck, drilling, canvas. For wash uniforms and bedding supplies for hospitals and hotels.	24 to 30 Cotton E Silk Twist 60 to 80 Linen
21	Bags, Coarse Cloths and Heavy Goods.	40 to 60 Linen or very Coarse Cotton

When sending orders for needles be sure to specify the size required.

**You will obtain the best stitching results from your Sewing Machine if it is fitted with a Singer Needle.**





**This Trade Mark  
is on the Arm of Every  
Singer Sewing Machine**



FORM 19695

(641)

PRINTED IN U. S. A.

## THE EDGE-STITCHER

This useful attachment is fastened to the machine in place of the presser foot, and will be found an indispensable aid whenever stitching must be kept accurately on the extreme edge of a piece of

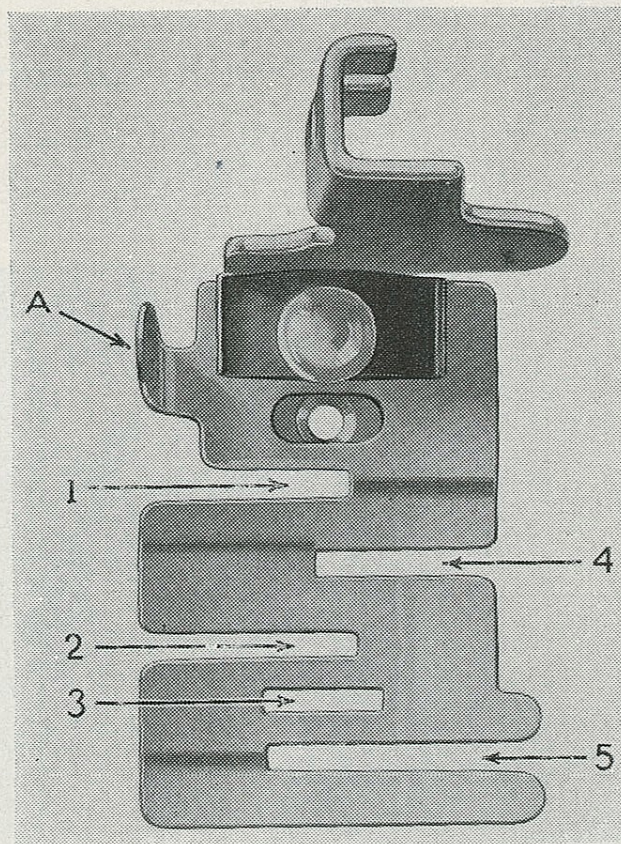

FIG. 1 THE EDGE-STITCHER

material. The slots, numbered from 1 to 5 in Fig. 1, serve as guides for sewing together laces, insertions and embroideries, sewing in position hemmed or folded edges, piping or sewing flat braid to a garment.

Copyright, U. S. A., 1923, 1938 and 1941,  
by The Singer Manufacturing Co.  
All Rights Reserved for All Countries



## Adjusting the Edge-Stitcher

After attaching the edge-stitcher to the machine, turn the balance wheel slowly by hand to see that the needle goes through the center of the needle hole. The distance of the line of stitching from the edge of the material in the slots can be regulated by pushing the lug (A, Fig. 1) to the right or left. If it moves hard, put a drop of oil under the blue spring, then wipe it dry.

## Sewing Lace Together with the Edge-Stitcher

It is difficult to sew two lace edges together even after basting, but the edge-stitcher makes it pos-

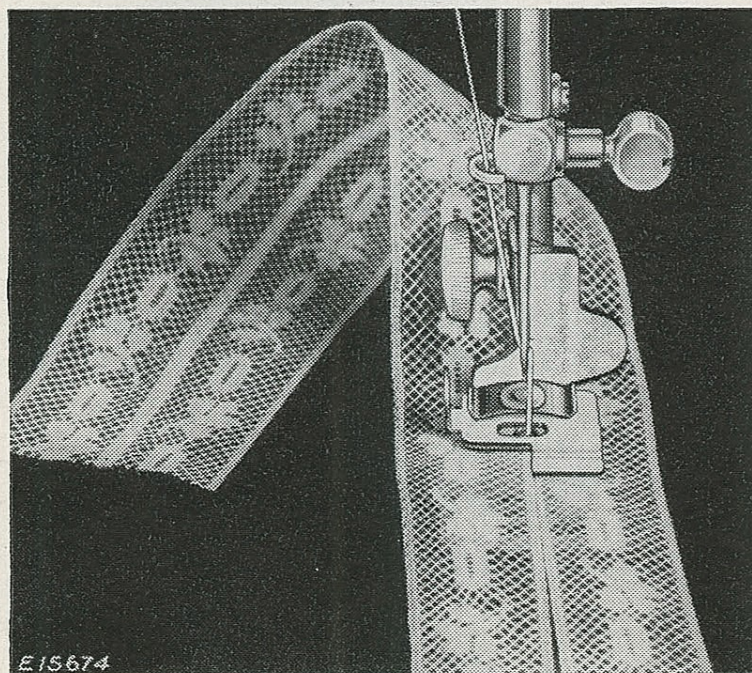

FIG. 2 SEWING LACE TOGETHER

sible to stitch on the very edge. Place one edge in slot 1 and the other in slot 4, and adjust lug (A, Fig. 1) until both edges are caught by the stitching. Hold the two pieces slightly overlapped to keep them against the ends of the slots. The thread tensions should be loose to avoid puckering of fine lace.



Lace and ribbon or other insertions can be set in by using the same slots (1 and 4, Fig. 1). The ma-

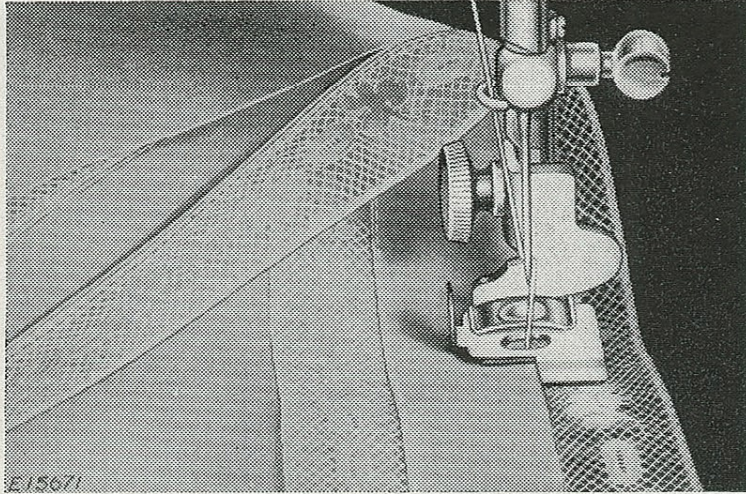

FIG. 3. SETTING IN LACE INSERTION

terial may be folded over before placing it in the slot so that a double thickness is stitched and will not pull out. The surplus material is trimmed away close to the stitching as shown in Fig. 3.

### **Piping with the Edge-Stitcher**

Piping is very attractive if the correct contrasting color is chosen for the piping material. Place the piping, with its finished edge to the left, in slot 3 (Fig. 1). Place the edge to be piped in slot 4, as shown in Fig. 1.

Piping should preferably be cut bias, and should be cut to twice the width of the slot (3, Fig. 1) in the edge-stitcher so that it can be folded once.

### **Applying Bias Folds with the Edge-Stitcher**

Folded bias tape or military braid, used for neat and colorful trimming, may be sewn on by placing the garment under the edge-stitcher the same as under a presser foot, and placing the tape in slot 1 or 4 (Fig. 1). To make a square corner, sew until the turning point is reached, then remove the tape



from the attachment and form the corner by hand, replace it in the slot and continue stitching, as

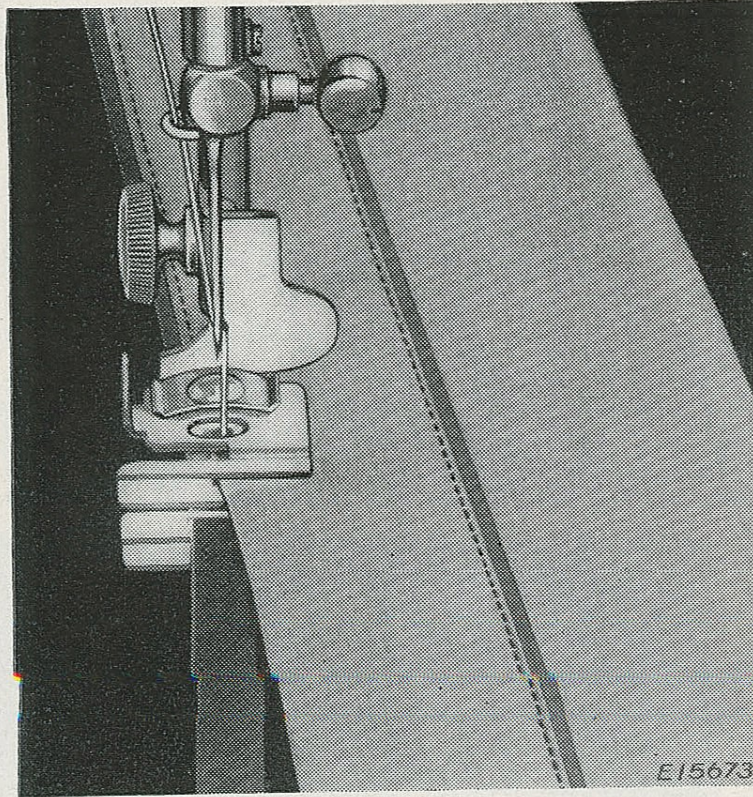

FIG. 4. PIPING WITH THE EDGE-STITCHER

shown in Fig. 5. To space two or more parallel rows, a guide line such as a crease, chalk mark or basting thread should be used.

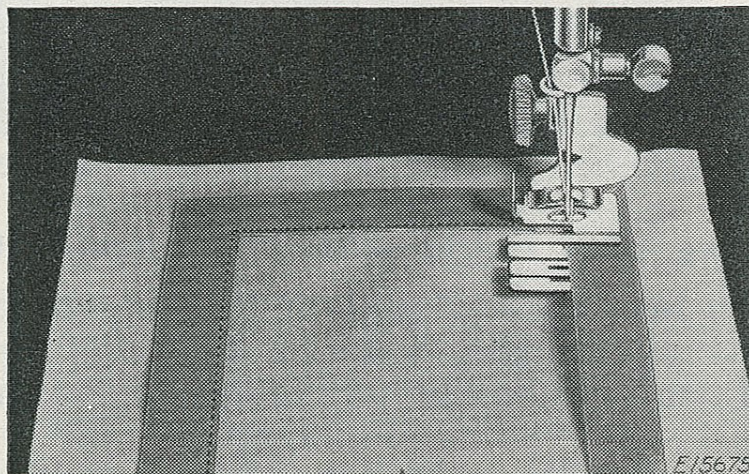

FIG. 5. APPLYING BIAS FOLDS WITH THE EDGE-STITCHER



## Stitching a Wide Hem with the Edge-Stitcher

A wide hem on sheets, pillow slips, etc., may be stitched evenly with the edge-stitcher after the hem

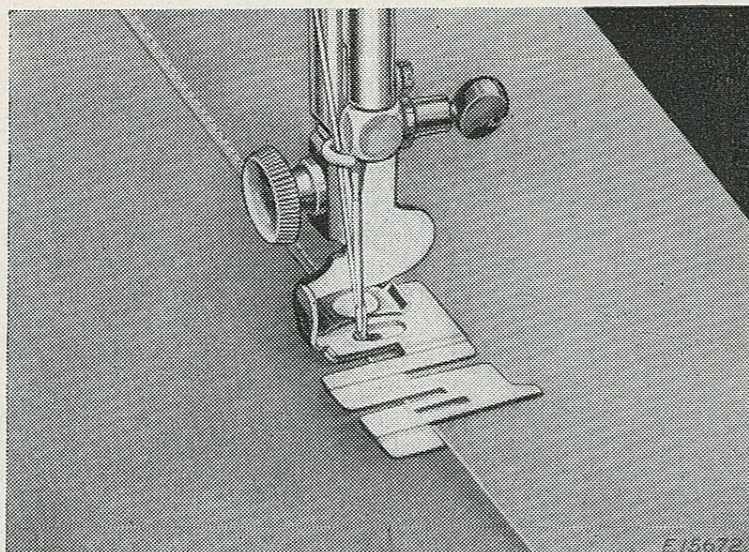

FIG. 6. MAKING A WIDE HEM

has been measured and the edge turned. Insert the edge in slot 5 as shown in Fig. 6 and adjust to stitch as close to the edge as desired.

## Making a French Seam

An even French seam may be made by inserting the two edges to be joined, wrong sides together, in slot 1 or 2 and stitching close to the edge; then folding both right sides together and inserting the back of the seam into slot 1 again and stitching with just enough margin to conceal the raw edges. See Fig. 7.

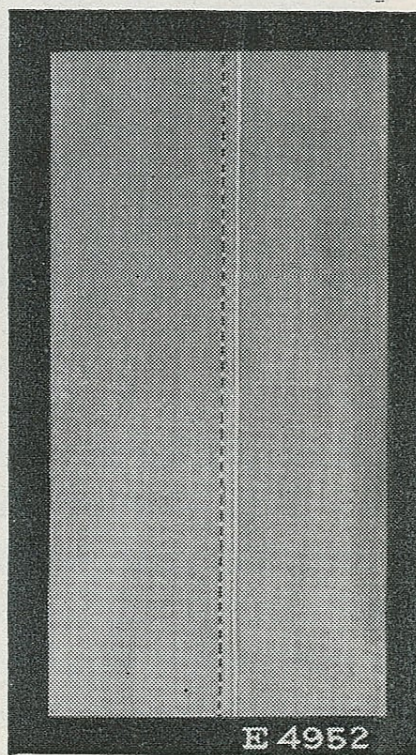

FIG. 7. A FRENCH SEAM



## Tucking with the Edge-Stitcher

Dainty narrow tucking may be produced on the edge-stitcher by inserting creased folds in slot 1 as

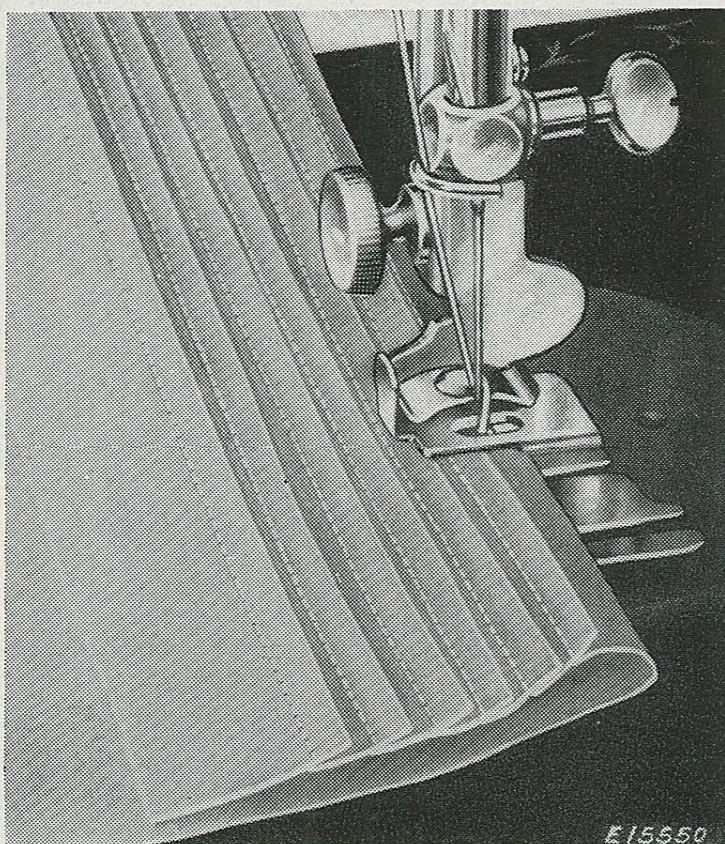

FIG. 8. TUCKING WITH THE EDGE-STITCHER

shown in Fig. 8, and adjusting the edge-stitcher to right or left for the desired width of tuck, up to  $\frac{1}{8}$  inch. Successive tucks may be easily creased by folding the material at the desired distance from the previous tuck, and then running the length of the fold over a straight edge such as the edge of the sewing machine cabinet. The secret of good tucking lies in a light tension, short stitch, and fine thread and needle.



## SHIRRING WITH THE GATHERER

The gatherer is fastened to the machine in the same manner as the presser foot. Material placed under the gatherer and stitched in the usual way will be slightly gathered. Any fabric that drapes well is especially suited for shirring with the gatherer. Most shirring with the gatherer is done with a long stitch and tight tension. To increase the fullness of the gathers, lengthen the stitch. To decrease the fullness, shorten the stitch.

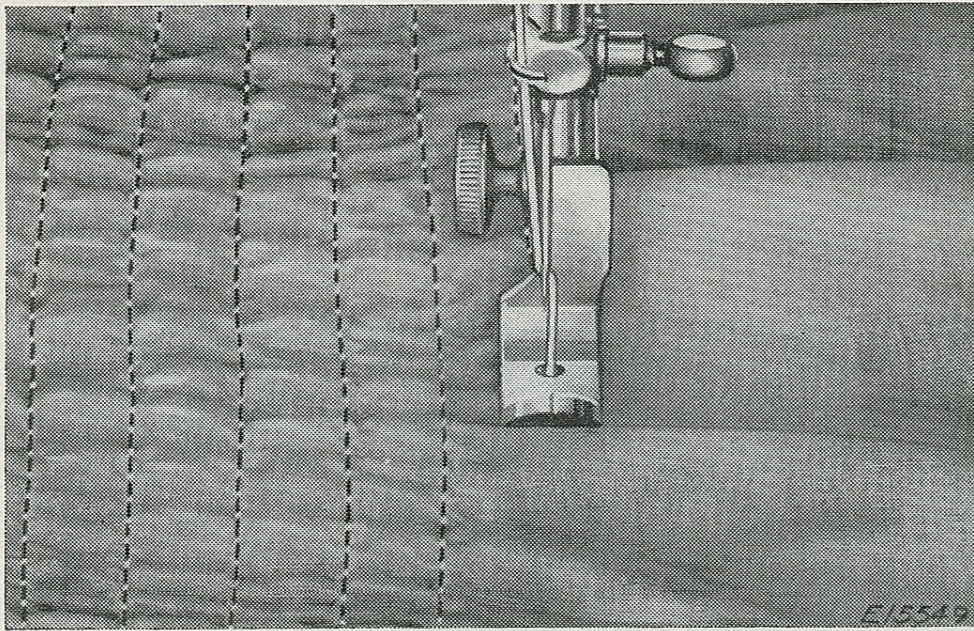

FIG. 9. THE GATHERER IN OPERATION

With the gatherer, it is possible to shirr in narrow rows as shown in Fig. 9. The material may be guided as easily as when sewing with the presser foot. Fine materials, such as batiste, silk or net, may be very attractively shirred. Where only a slight fullness is required, as at the top of a sleeve or around the neck, the gatherer will be found very convenient.



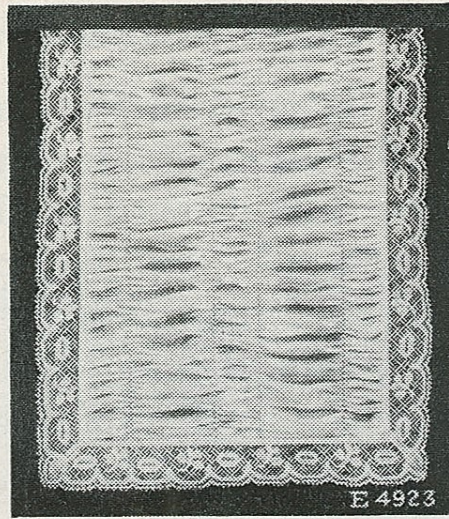

FIG. 10. SHIRRING

A very pleasing effect may be gained by using thread or embroidery silk of contrasting color on the bobbin. Fig. 11 shows a white organdie collar and cuff set with red and green smocking made with the gatherer, using fine crochet cotton or tatting thread on the top and white cotton on the bobbin.

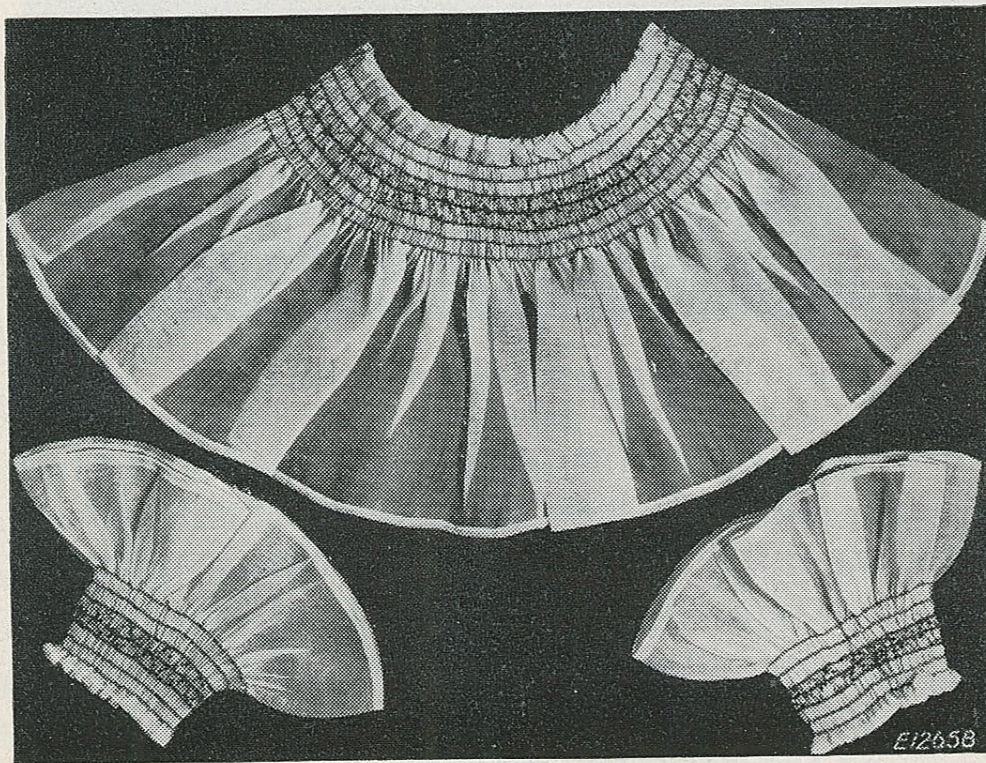

FIG. 11. SMOCKING